

# INSTALLATION, SERVICE & PARTS MANUAL

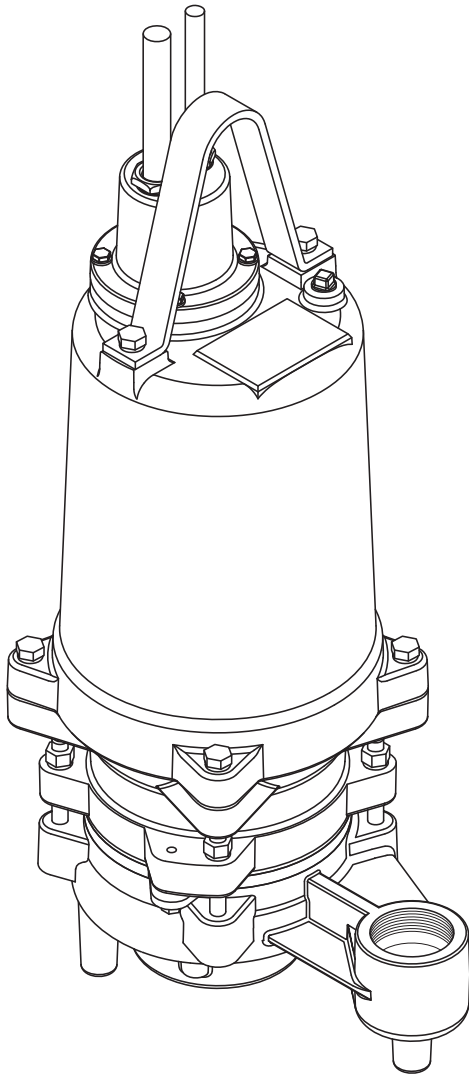

**Series: PFG3022, PFG3062,  
PFG3032, PFG3042,  
PFG5022, PFG5062,  
PFG5032, PFG5042,  
PFG7532, PFG7542**

**3, 5 & 7.5HP•3450RPM•60Hz  
Submersible Grinder Pump**



## **Power-Flo Pumps & Systems**

*a Power-Flo Technologies company*

**General Safety Information**

Before installation, read the following instructions carefully. Failure to follow instruction and Safety information could cause serious bodily injury, death and/or property damage. Each Power-Flo pump is individually factory tested to insure proper performance. Closely following these instructions will eliminate potential operating problems, assuring years of trouble-free service.

**▲ DANGER** "Danger" indicates an imminent hazardous situation which, if not avoided, WILL result in death or serious injury.

**▲ WARNING** "Warning" indicates a hazardous situation which, if not avoided, MAY result in death or serious injury.

**▲ CAUTION** "Caution" indicates a hazardous situation which, if not avoided, MAY result in minor or moderate injury.

**IMPORTANT - Power-Flo Pumps and Systems is not responsible for losses, injury or death resulting from failure to observe these safety precautions, misuse, abuse or misapplication of pumps or equipment.**

**▲ DANGER** All returned Products must be Cleaned, sanitized, Or decontaminated Prior to shipment, to insure employees will not be exposed to health hazards in handling said material. All applicable laws and regulations shall apply.

**▲ WARNING** Bronze/brass fitted pumps may contain levels higher than considered safe for potable water systems. Government agencies have determined that leaded copper alloys should not be used in potable water applications.

**▲ WARNING** Installation, wiring, and junction connections must be in accordance with the National Electric Code and all applicable state and local codes. Requirements may vary depending on usage and location.

\* Power-Flo is a registered trademark of Power-Flo Technologies Inc. Other brand and product names are trademarks or registered trademarks of their respective holders. Alteration Rights Reserved. 5/08, 6/09, 9/09, 5/10, 11/10, 1/12, 5/12, 8/12, 11/12, 2/13, 5/13, 8/17, 9/2020, 1/2021

**▲ WARNING** Installation and servicing is to be conducted by qualified personnel only.

**▲ DANGER** Keep clear of suction and discharge openings. **Do not** insert fingers in pump with power connected.

**▲ WARNING** Always wear eye protection when working on pumps. Do not wear loose clothing that may become entangled in moving parts

**▲ DANGER** Pumps build up heat and pressure during operation. Allow time for pumps to cool before handling or servicing.

**▲ DANGER** This pump is **not** intended for use in swimming pools or water installations where human contact with pumped fluid. Pumps when used as a decorative water fountain pump **MUST** be used in circuit protected by a Ground Fault Interrupter.

**▲ DANGER** Risk of electric shock. To reduce risk of electric shock, always disconnect pump from power source before handling. **Lock out power & tag.**

**▲ WARNING** **Do not** use these pumps in water over 104°F. **Do not** exceed manufactures recommended maximum performance, as this could cause the motor to overheat.

**▲ DANGER** **Do not** lift, carry or hang pump by the electrical cables. Damage to the electrical cables can cause shock, burnes or death. **Never** handle connected power cords with wet hands. Use appropriate lifting device.

**▲ WARNING** Sump and sewage pumps often handle materials which could cause illness or disease. wear adequate protective clothing when working on a used pump or piping. Never enter a basin after it has been used.

**▲ DANGER** Failure to permanently ground the pump, motor and controls before connecting to power can cause shock, burns or death.

**▲ DANGER** These pumps are **NOT** to be installed in locations **classified as hazardous** in accordance with the National Electric Code, ANSI/NFPA 70.

**▲ WARNING** **DO NOT** introduced into any sewer, either directly, or through a kitchen waste disposal unit or toilet: **Seafood Shells, Aquarium Gravel, Cat Litter, Plastic Objects (toys, utensils, etc.), Sanitary Napkins or Tampons, Diapers, Rags, Disposable Wipes or Cloth, Medications, Flammable Material, Oil or Grease, Strong Chemicals, Gasoline.**

**WARNING:** CANCER AND REPRODUCTIVE HARM- WWW.P65WARNINGS.CA.GOV

**IMPORTANT!** Prior to installation, record Model Number, MFG Date, Amps, Voltage, Phase and HP, from pump name plate for future reference. Also record the Voltage and Current Readings at Startup:

1 Phase Models	
Amps:	Volts:
3 Phase Models	
Amps L1-2:	Volts L1-2:
Amps L2-3:	Volts L2-3:
Amps L3-1:	Volts L3-1:

Model Number: \_\_\_\_\_

MFG Date: \_\_\_\_\_

PHASE: \_\_\_\_\_ HP: \_\_\_\_\_

**Specifications**

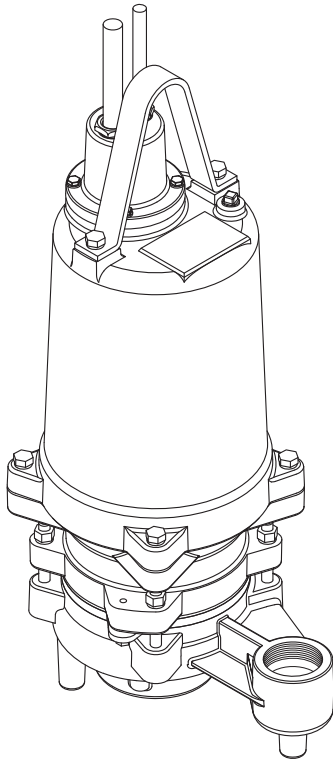

**Series: PFG3022,  
PFG3062, PFG3032,  
PFG3042, PFG5022,  
PFG5062, PFG5032,  
PFG5042, PFG7532,  
PFG7542**

**3, 5 & 7.5HP•3450RPM•60Hz  
Submersible Grinder Pump**

**Description**

Designed to reduce domestic, commercial, institutional and light industrial sewage to a finely ground slurry.

<b>DISCHARGE</b>	2" NPT Vertical, Bolt-on Flange
<b>LIQUID TEMPERATURE</b>	104°F (40°C) Intermittent
<b>VOLUTE</b>	Cast Iron, Class 30
<b>MOTOR HOUSING</b>	Cast Iron, Class 30
<b>SEAL PLATE</b>	Cast Iron, Class 30
<b>IMPELLER</b>	Cast Iron, Class 30
<b>SHREDDING RING</b>	Stainless Steel
<b>CUTTER</b>	Stainless Steel
<b>SHAFT</b>	Stainless Steel
<b>SQUARE RINGS</b>	Buna-N
<b>HARDWARE</b>	Stainless Steel
<b>PAINT</b>	Air dry enamel
<b>SEAL</b>	Tandem Double Mechanical, Oil Filled Reservoir, Upper -Carbon/Ceramic/Buna-N, Lower - Silicon Carbide/Silicon Carbide/Viton Stainless Hardware
<b>UPPER BEARING</b>	Single row, Ball, Oil Lubricated
<b>INTERMEDIATE BEARING</b>	Single row, Ball, Oil Lubricated
<b>LOWER BEARING</b>	Sleeve, Oil Lubricated
<b>POWER CORD</b>	30 ft. Cord . Pressure grommet for Sealing and Strain Relief.
<b>MOTOR</b>	Oil Filled, Squirrel Cage Induction, Class F Insulation
<b>SINGLE PHASE</b>	Capacitor Start/Capacitor Run. Requires overload protection in the control panel, Requires starter or control panel which includes capacitors.
<b>THREE PHASE</b>	Dual Voltage 230/460. Requires overload protection in control panel
<b>MOISTURE SENSOR</b>	Normally Open (NO). Requires relay in control panel
<b>TEMPERATURE SENSOR</b>	Normally Closed (NC). Requires relay in control panel



**Specifications**

MODEL	HP	Hz	Volts/Ph	RPM	Full Load Amps	Locked Rotor Amps	NEMA Start Code	Cord Type	Cord Size	Cord O.D.
PFG3022*⊕	3	60	230/1	3450	26	90	H	SOW	10/4	.75
PFG3062	3	60	208/3	3450	17	65	J	SOW	10/4	.75
PFG3032	3	60	230/3	3450	14.5	62	K	SOW	10/4	.75
PFG3042	3	60	460/3	3450	7.2	31	K	SOW	10/4	.75
PFG5022*	5	60	230/1	3450	39	136	H	SOW	10/4	.75
PFG5062	5	60	208/3	3450	25	122	K	SOW	10/4	.75
PFG5032	5	60	240/3	3450	21.9	120	L	SOW	10/4	.75
PFG5042	5	60	460/3	3450	11	60	L	SOW	10/4	.75
PFG7532	7.5	60	230/3	3450	22.3	136	J	SOW	10/4	.75
PFG7542	7.5	60	460/3	3450	11.2	68	J	SOW	10/4	.75

Moisture & Temperature sensor cable for all other models is 18/5 SOW. 0.47 inches O.D. See page 17 for Relay kits.

(\*) **IMPORTANT!** - These pumps require a control panel with start, run capacitors and relay. Capacitor kits which include Start & Run capacitors and Start Relay, are available if a Power-Flo control panel is not used, see page 17.

**Recommended Breaker & Heater Sizes**

MODEL	HP	Hz	Volts/Ph	Breaker Size	Heater Size **	Voltage Relay	Start Capacitor	Run Capacitor
PFG3022*⊕	3	60	230/1	80 AMP	K-70	MARS 64	189-227 mfd-220 volt	40 mfd - 370 volt
PFG3062	3	60	208/3	40 AMP	K-56	N/R	N/R	N/R
PFG3032	3	60	230/3	30 AMP	K-54	N/R	N/R	N/R
PFG3042	3	60	460/3	15 AMP	K-41	N/R	N/R	N/R
PFG5022*	5	60	230/1	80 AMP	K-70	MARS 64	189-227 mfd-220 volt	40 mfd - 370 volt
PFG5062	5	60	208/3	50 AMP	K-63	N/R	N/R	N/R
PFG5032	5	60	240/3	50 AMP	K-62	N/R	N/R	N/R
PFG5042	5	60	480/3	20 AMP	K-50	N/R	N/R	N/R
PFG7532	7.5	60	230/3	50 AMP	K-67	N/R	N/R	N/R
PFG7542	7.5	60	460/3	30 AMP	K-54	N/R	N/R	N/R

N/R = Not Required

Winding resistance ± 5% at terminal block. Rated operation at ± 10% voltage at motor.

(\*\*) Recommended heater sizes may vary depending on pump station requirements.

(⊕) This data is for the PFG3022, from Sept 2010 and newer. For units prior to Sept 2010 use to following: FLA - 21.7, LRA - 75, NEMA code - G, Breaker Size - 50amp, Heaters K-64, Relay MARS 65, Start Cap. 257mfd - 220volts, Run Cap. 20mfd-370volts.

**Performance**

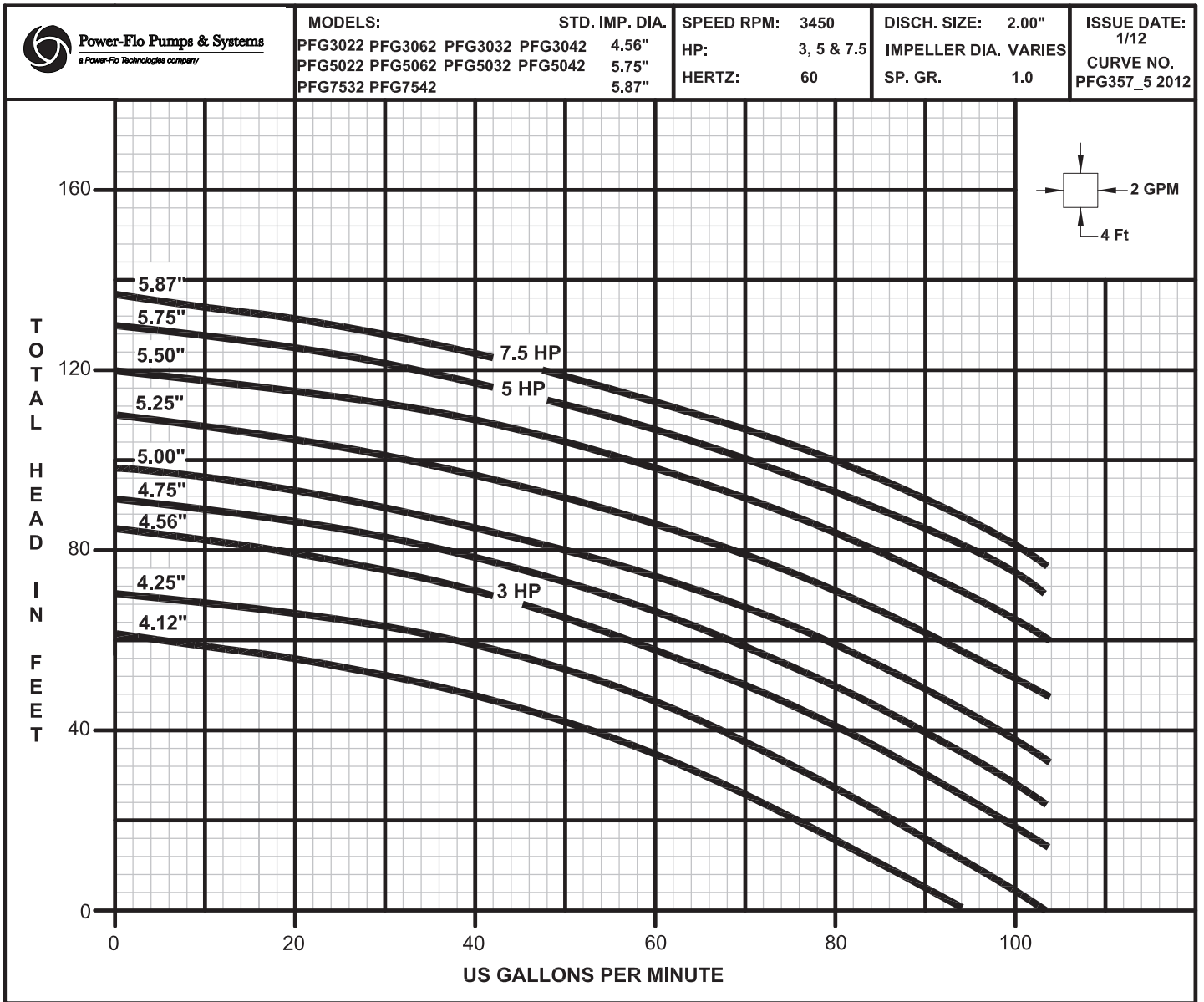

**Dimensions**

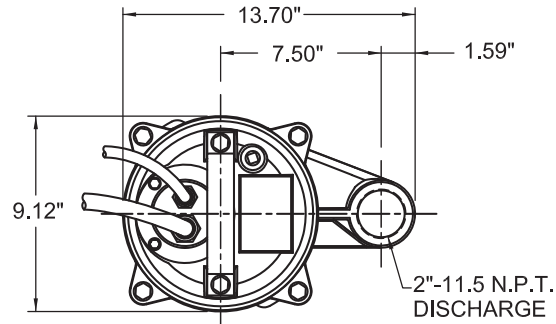
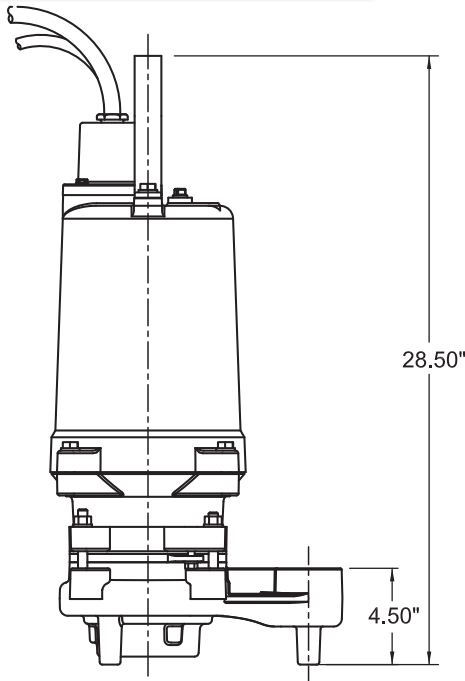

**IMPORTANT!** - Pump Suction **MUST** be a minimum of 4" from basin floor with use of legs, stand or slide rail system.

**Receiving & Installation**

**Receiving Inspection**

Upon receiving the pump, it should be inspected for damage or shortages. If damage has occurred, file a claim immediately with the company that delivered the pump. If the manual is removed from the packaging, do not lose or misplace.

**Storage**

Any product that is stored for a period longer than six (6) months from the date of purchase should be bench tested prior to installation. A bench test consists of, checking the impeller to assure it is free turning and a run test to assure the motor (and switch if provided) operate properly. Do not pump out of liquid.

**Controls**

PFG series grinders require a separate approved pump control device or panel for automatic operation. Be sure the electrical specification of the control selected properly match the electrical specifications of the pump.

**Location**

The grinder pump is designed to fit in basin or wetwell by using a slide rail system.

**IMPORTANT!** - A CLEARANCE UNDER THE PUMP FOR ENTRANCE OF SEWAGE SOLIDS MUST BE A MINIMUM OF 3 INCHES TO A MAXIMUM OF 4.5 INCHES.



**Submergence**

The pump should always be operated in the submerged condition. The minimum sump liquid level should never be less than above the pump's volute (See Figure 1).

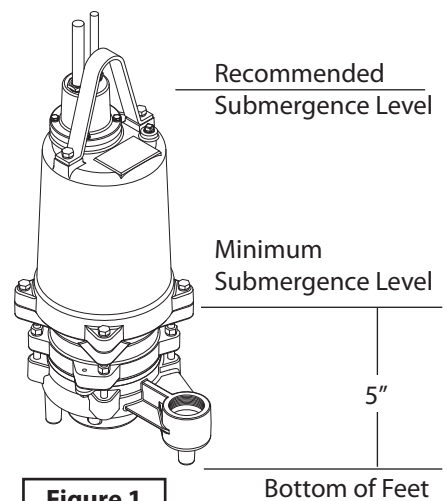

**Figure 1**

**Receiving & Installation**

**Installation**

There are several methods of installing grinder pumps. See contract plans and/or specification: A slide rail in a package system or concrete wet well is the most common, which allows the pump(s) to be installed or removed without requiring personnel to enter the wet well.

The sump or basin shall be sealed and vented in accordance with local plumbing codes. **This pump is designed to pump grinder or wastewater, nonexplosive and noncorrosive liquids and shall NOT be installed in locations classified as hazardous in accordance with the National Electrical Code (NEC) ANSI/NFPA 70 or Canadian Electric Code (CEC).** The pump should never be installed in a trench, ditch, or hole with a dirt bottom. The legs will sink into the dirt and the suction will become plugged. The installation should be at a sufficient depth to ensure that all plumbing is below the frost line. If this is not feasible, remove the check valve and size the basin to accommodate the additional backflow volume.

**Discharge Piping**

Discharge piping should be as short as possible and sized no smaller than the pump discharge. **Do not reduce the discharge pipe size below that which is provided on the pump.** Both a check valve and a shut-off valve are recommended for each pump. The check valve is used to prevent backflow into the sump. The shut-off valve is used to manually stop system flow during pump servicing.

**Liquid Level Controls**

The level control(s) should be mounted on the discharge piping, a cable rack or float pole. The level control should have adequate clearance so it cannot hang up in its swing and that the pump is completely submerged when the level control is in the "Off" mode. By adjusting the cord tether the control level can be changed. One cycle of operation should be observed, so that any potential problems can be corrected.

It is recommended that the level control float should be set to insure that the liquid in the sump never drops below the top of the motor housing or a minimum level of 10 inches above the basin floor.

**Electrical Connections**

**Power cable** - The power cable mounted to the pump must not be modified in any way except for shortening to a specific application. Any splice between the pump and the control panel must be made in accordance with the electric codes. It is recommended that a junction box, if used, be mounted outside the sump or be of at a minimum Nema 4 construction if located within the wet well. **DO NOT USE THE POWER CABLE TO LIFT PUMP.**

Always rely upon a Certified Electrician for installation.

**Thermal Protection:**

The normally closed (N/C) over temperature sensor is embedded in the motor windings and will detect excessive heat in the event an overload condition occurs. The thermal sensor will trip when the windings become too hot and will automatically reset when the pump motor cools to a safe temperature. It is recommended that the thermal sensor be connected in series to an alarm device to alert that an overtemperature condition and/or motor starter coil to stop pump.

In the event of an overtemperature, the source of this condition should be determined and repaired immediately. Thermal protection shall not be used as a motor overload device. A separate motor overload device must be provided in accordance with NEC code.



**WARNING! - DO NOT LET THE PUMP CYCLE OR RUN IF AN OVERLOAD CONDITION OCCURS!**

If current through the temperature sensor exceeds the values listed, an intermediate control circuit relay must be used to reduce the current or the sensor will not work properly.

TEMPERATURE SENSOR ELECTRICAL RATINGS		
Volts	Continuous Amperes	Inrush Amperes
110-120	3.00	30.0
220-240	1.50	15.0
440-480	0.75	7.5
600	0.60	6.0

**Moisture Sensor:**

To detect any moisture present a normally open (N/O) probe is installed in the seal chamber. The probe should be connected in series to an alarm device or motor starter coil to alert the operator that moisture has been detected. Check the probe leads for continuity, ( $\infty$  resistance = no moisture). Also check the junction box and control panel for moisture content as this may induce a false signal. **IF MOISTURE DETECTION OCCURS, MAINTENANCE SHOULD BE DONE TO IDENTIFY AND REPAIR.**



**Installation & Service**

**Wire Size:**

If longer power cable is required consult a qualified electrician for proper wire size.

**Pre-Operation**

1. **Check Voltage and Phase**  
Compare the voltage and phase information stamped on the pump name plate.
2. **Check Pump Rotation** - Improper motor rotation can result in poor pump performance and can damage the motor and/or pump. Check rotation on three phase units by momentarily applying power and observe the "kickback".

Kickback should always be in a counter-clockwise direction as viewed from motor end or opposite to impeller rotation. Incorrect rotation for Single-Phase pumps is unlikely. If the rotation is incorrect contact factory.

3. **Name Plate** - Record the information from the pump name plate to drawing in front of manual for future reference.
4. **Insulation Test** - An insulation (megger) test should be performed on the motor. Before the pump is put into service. The resistance values (ohms) as well as the voltage (volts) and current (amps) should be recorded.
5. **Pump-Down Test** - Be sure pump has been properly wired, lowered into the basin, sump or lift station, check the system by filling with liquid and allowing the pump to operate through its pumping cycle. The time needed to empty the system, or pump-down time along with the volume of water, should be recorded.

**Maintenance**

No lubrication or maintenance is required. Perform the following checks when pump is removed from operation or when pump performance deteriorates:

- a). Inspect motor chamber for oil level and contamination.
- b). Inspect impeller and body for excessive build-up or clogging.
- c). Inspect motor and bearings.
- d). Inspect seal for wear or leakage.

**Servicing**

NOTE: Item numbers in ( ) refer to Figures 7 & 8.

**Cooling Oil** - Anytime the pump is removed from operation, the cooling oil in the motor housing should be checked visually for oil level and contamination. To check oil, set unit upright. Remove pipe plug (30) from housing (8). With a flashlight, visually inspect the oil in housing (8) to make sure it is clean and clear, light amber in color and free from suspended particles. Milky white oil indicates the presence of water. Oil level should be just above the motor when pump is in vertical position.

**Oil Testing**

- Drain oil into a clean, dry container by placing pump on it's side, remove pipe plug (30), from housing (8).
- Check oil for contamination using an oil tester with a range to 30 Kilovolts breakdown.
- If oil is found to be clean and uncontaminated (measuring above 15 KV. breakdown), refill the housing.
- If oil is found to be dirty or contaminated (or measures below 15 KV. breakdown), the pump must be carefully inspected for leaks at the shaft seal, cable assembly, square ring and pipe plug, before refilling with oil. Tolocate the leak, perform a pressure test.

After leak is repaired, dispose of old oil properly, and refill with new oil.

**Pressure Test (If oil has been drained)**

Remove pipe plug (30) from housing (8). Apply pipe sealant to pressure gauge assembly and tighten into hole. Pressurize motor housing to 10 P.S.I. Use soap solution around the sealed areas and inspect joints for "air bubbles".

If, after five minutes, the pressure is still holding constant, and no "bubbles" are observed, slowly bleed the pressure and remove the gauge assembly. Replace oil. Leek must be located and repaired if pressure does not hold.

**Pressure Test (If oil has NOT been drained)**

- Oil should be at normal level. Remove pipe plug (30) from housing (8). Apply pipe sealant to pressure gauge assembly and tighten into hole. Pressurize motor housing to 10 P.S.I. Use soap solution around the sealed areas above the oil level and inspect joints for "air bubbles". For sealed areas below oil level, leaks will seep oil. If, after five minutes, the pressure is still holding constant, and no "bubbles" / oil seepage is observed, slowly bleed the pressure and remove the gauge assembly. Replace oil. Leek must be located and repaired if pressure does not hold.

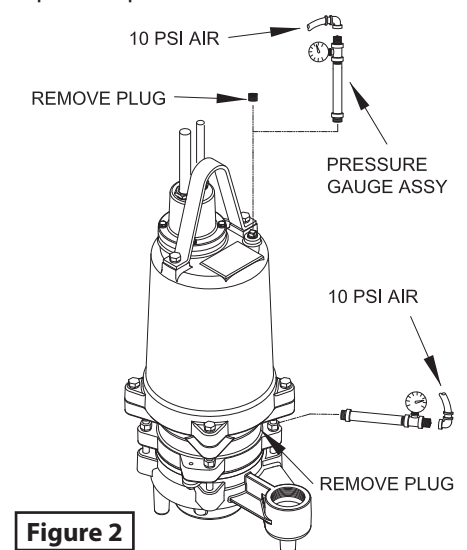

**Figure 2**





Pressure builds up extremely fast, increase pressure by "TAPPING" air nozzle. Too much pressure will damage seal. **DO NOT exceed 10 P.S.I.**

**Seal Chamber** - Set pump on its side with fill plug (30) downward, remove plug (30) and drain all oil from seal chamber. Apply pipe sealant to pressure gauge assembly and tighten into hole in intermediate coupling (5). Pressurize seal chamber to 10 P.S.I. and check for leaks.

**Oil Replacement:**

**Motor Housing** - Drain all oil (if not already done so) from motor housing and dispose of properly per Local and Environmental Standards.

Set pump upright and refill with new cooling oil, see "Cooling Oil" chart. Fill to just above motor as an air space must remain in the top of the motor housing to compensate for oil expansion. Apply pipe thread compound to threads of pipe plug (30) then assemble to motor housing (8).

**Seal Chamber** - Drain all oil (if not already done so) from seal chamber and dispose of properly per Local and Environmental Standards. Place pump on its side with plug (30) upward, and refill with new oil, see "Cooling Oil" chart. Apply pipe thread compound to threads of pipe plug (30) and assemble to intermediate coupling (5).



**DO NOT** overfill oil. Overfilling of housing with oil can create excessive and dangerous hydraulic pressure which can destroy the pump and create a hazard. Overfilling oil voids warranty.

Cooling Oil Recommended Supplier/Grade	
BP	Enerpar SE100
Conoco	Pale Paraffin 22
Mobile	D.T.E. Oil Light
Shell Canada	Transformer-10
Texaco	Diala-Oil-AX



**WARNING!** - Before any service work is done, disconnect and lock out electrical power to pump.

**Disassembly**

**Cutter** - Lay pump on its side and remove the cutter retaining screw (29) and washer (28). A small amount of heat may be needed to loosen screw. **DO NOT** overheat. Wedge a flat screwdriver between cutter and shredding ring and remove screw. With a hammer and punch, tap the cutter (27) counter-clockwise to remove.



**CAUTION!** - Cutter edges are very SHARP. Cutter must be removed before removing volute.

**Volute** - Remove hex nuts (25) and washers (9) from studs (26) and remove volute (23) and square ring (24) from pump.

**Shredding Ring** - To replace or reverse the shredding ring (20), remove allen screws (22) and lift throat (21) from volute (23) then press out using an arbor press. The shredding ring (20) can be pressed out and reversed when cutting edges dull.

**Impeller** - Remove impeller (18) by turning counter-clockwise while holding the motor shaft stationary with a screwdriver. **NOTE:** Seal spring is relaxed with impeller removed, some oil may seep from seal cavity. **Do Not** store pump without impeller in place.

**Outer Seal** - Handle seal parts with care. Remove seal (34) spring and rotating member from shaft. Examine all seal parts. Inspect contact faces for signs of uneven wear tracks on stationary, chips and scratches on either seal face. **DO NOT interchange seal components, replace the entire shaft seal (34).**

**Seal Plate** - Remove cap screws (35) and washers (38) from seal plate (19). Remove seal plate (19) and square ring (24) from intermediate coupling (5). With flat screwdriver, press out seal (34) stationary member. Inspect square ring (24) for cuts or abrasions.

**Cable Assemblies** - Remove Hex plugs (13B) and (14B), washers (13C) and (14C) and grommets (13D) and (14D) from conduit box (11).

**Motor** - Remove pipe plug (30) and drain oil if not already done so. Position pump upright using blocks or pvc pipe to avoid resting pump on the shaft. Remove cap screws (15) and lockwashers (16) from cable box assembly (11) and slide conduit box up the cords until motor lead wires are exposed. Disconnect connectors (17) from motor leads wires to remove cable assemblies (13) and (14). Remove ground screw (31). Remove and inspect o-ring (12).

Remove cap screws (10) and lockwashers (9) from motor housing (8). Vertically lift motor housing (8) from intermediate coupling (5) along with square ring (7), replace if cut or damaged. Remove motor bolts and carefully remove stator housing from rotor. Remove retaining ring (2) from intermediate (5) and pull rotor out with bearing (3) and rotating member of inner seal.



**Service**

Inspect motor winding for shorts and check resistance values. Check rotor for wear. If rotor or the stator windings are defective, the complete motor must be replaced.

**Bearings & Inner Seal** - Remove seal (4) rotating member and spring from rotor shaft. Press stationary from intermediate (5) with flat screwdriver. Examine all seal parts. Inspect contact faces for signs of uneven wear tracks on stationary, chips and scratches on either seal face. **DO NOT interchange seal components, replace the entire shaft seal (4).** Remove retaining rings (6) from shaft. Using a wheel puller or arbor press remove bearing (3) from shaft. Remove upper motor bearing from shaft with a bearing puller. (See Figure 3)

Check sleeve bearing (39) for excessive wear, if replacement is required the complete intermediate coupling (5) should be replaced.

**Moisture Probes** - Remove screws (37) and wire (33) from probes (36). Remove probes (36) from intermediate (5).



**IMPORTANT! - All parts must be clean before reassembly. Handle seal parts with extreme care. DO NOT damage lapped surfaces.**

**Reassembly**

**Moisture Probes** - Apply thread compound to thread on probes (36) and install in intermediate (5). Connect wires (33) with screws (37).

**Bearings** - Be careful not to damage the rotor shaft when replacing bearings. Using an arbor press, hold the rotor and press the upper bearing on the rotor shaft, applying force to the inner race of the bearing only. Replace upper retaining ring onto rotor shaft. In the same manner replace lower bearing (3) onto rotor shaft. Place lower retaining rings (6) onto shaft.

**Inner Seal** - Clean and oil seal cavity in intermediate coupling (5). Lightly oil (**Do not use grease**) outer surface of stationary member. Press seal's (4) stationary member firmly into intermediate coupling (5), using a seal tool or pipe.

Nothing should come in contact with the seal face except the seal tool. Be sure the stationary is in straight. Place seal's (4) retaining ring and spring over shaft until seated on shaft shoulder. Slide a bullet tool over rotor shaft threads. Lightly oil (**Do not use grease**) shaft, bullet, and inner surface of bellows on rotating member, with finished end away from motor, slide rotating member over bullet and onto shaft until it engages spring. Make sure spring is seated in retaining ring and spring is lined up on rotating member and not cocked or resting on bellows tail. (See Figure 3)

**Motor** - Slide rotor/shaft with bearing (3) and seal parts (4) into intermediate coupling (5) until bearing seats into intermediate coupling. Install retaining ring (2) into intermediate coupling (5). Place motor stator over rotor, lining up motor bolts with holes in intermediate coupling (5). Place end bell on top of motor and insert motor bolts and torque to 17 in-lbs.

**Wiring Connections** - Set square ring (7) in groove on intermediate coupling (5). Pull wires through opening in top of motor housing (8) while lowering motor housing onto intermediate coupling (5). Insert capscrews (10) with lockwasher (9) through motor housing into intermediate and tighten. Place square ring (12) on motor housing (8). Place conduit box with cables next to motor housing and make wire connections (see Figure 4). Connect ground wire (42) with screw (31) to conduit box (11) if disconnected.

Check power cable (13) and control cable (14) for damage and replace complete conduit box and cable assembly if required.

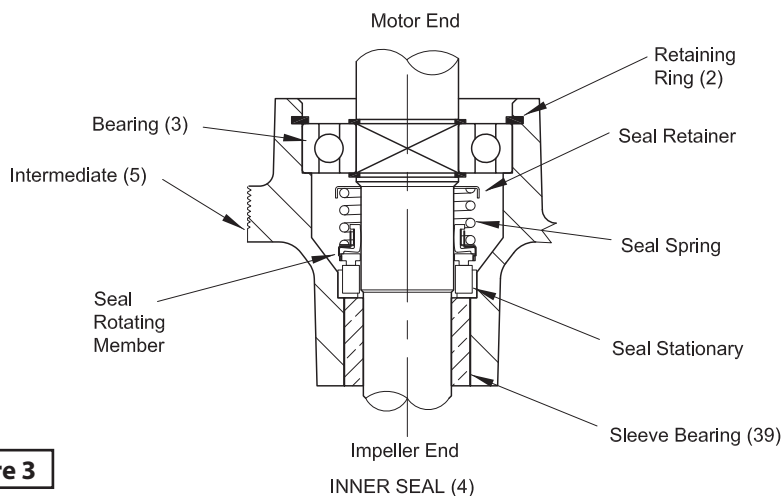

**Figure 3**

Pump Wiring Schematics

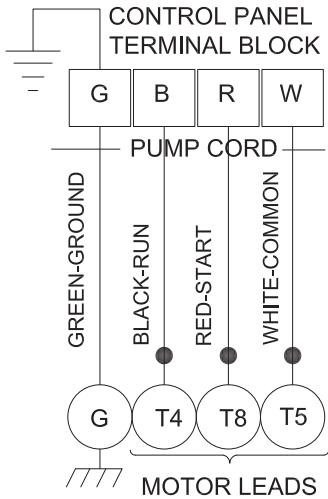

FIGURE 4 - SINGLE PHASE 230 VOLT AC

Power Cable	Motor Lead Number
Green (Ground)	Green
Black	4 run (Main)
Red	8 start
White	5 common

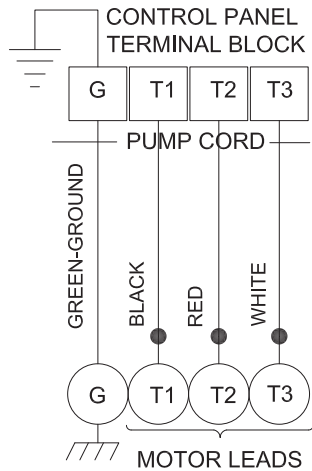

FIGURE 4 - THREE PHASE 208 VOLT AC

Power Cable	Motor Lead Number
Green (Ground)	Green
Black	1
Red	2
White	3

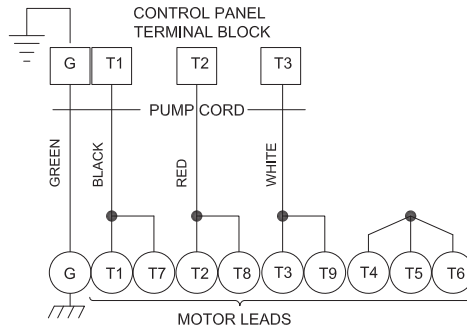

FIGURE 4 - THREE PHASE 230 VOLT AC

Power Cable	Motor Lead Number
Green (Ground)	Green
Black	1 & 7
Red	2 & 8
White	3 & 9
	T4, T5 & T6 Together

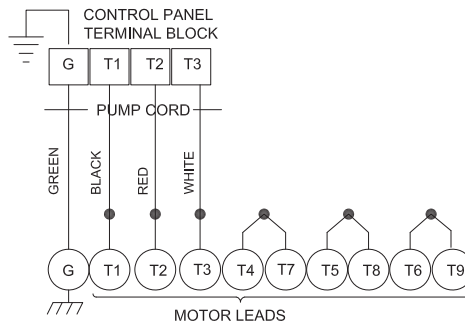

FIGURE 4 - THREE PHASE 460 VOLT AC

Power Cable	Motor Lead Number
Green (Ground)	Green
Black	1
Red	2
White	3
	T4 & T7 Together
	T5 & T8 Together
	T6 & T9 Together

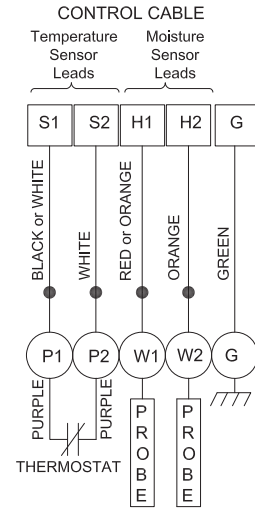

FIGURE 4 MOISTURE & TEMPERATURE SENSORS

Control Cable	Lead Number
Green (Ground)	Green
Black or White	P1 (Temp Sensor) In series with starter coil
White	P2 (Temp Sensor) In series with starter coil
Red or Orange	W1 (Moisture Sensor)
Orange	W2 (Moisture Sensor)

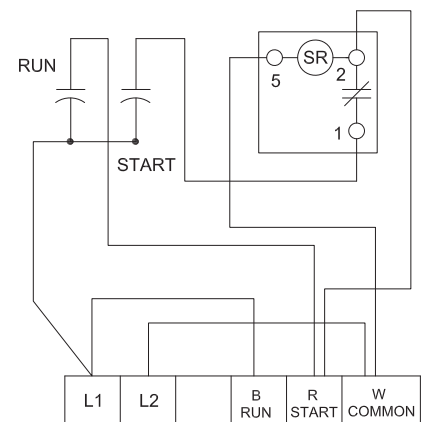
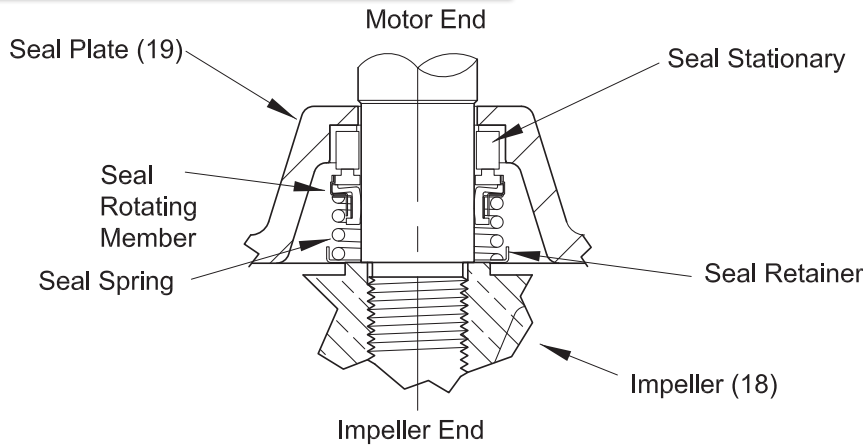

FIGURE 4 1 Phase Capacitor Pack for Control Panel



**Service**



**Figure 5**

**OUTER SEAL (34)**

Place conduit box (11) on motor housing (8) and insert capscrews (15) with washers (16) into motor housing and torque to 16 ft/lbs.

**Cable Assemblies** - Power cable, Place one friction ring (13C), grommet (13D), one friction ring (13C) and hex plug (13B) into conduit box (11). Control Cable, Place one friction ring (14C), grommet (14D), one friction ring (14C) and hex plug (14B) into conduit box (11). Torque hex plugs to 15 ft. lbs. to prevent leakage. See Figures 7 & 8.

**Seal Plate** - Lubricate and set square ring (24) in bottom groove of seal plate (19). Place seal plate (19) over shaft and onto intermediate coupling (5), being sure square ring (24) is not twisted and in the groove. Place two capscrews (35) with lockwashers (38) into seal plate and torque to 6.5 ft/lbs.

**Outer Seal** - Clean and oil stationary seal cavity in seal plate (19). Slide seal guide tool over motor shaft. Lightly oil (**Do not use grease**) outer surface of seal's (34) stationary member.

Press stationary firmly into seal plate (19) using a seal pusher tool. Be sure the stationary member is in straight. Nothing but the seal tool is to come in contact with seal face. (See Figure 5)



**IMPORTANT! Do not hammer on the seal pusher. It will damage the seal face.**

With seal guide tool over motor shaft, Lightly oil (**Do not use grease**) guide, shaft and inner surface of bellows on rotating seal.

With lapped surface of rotating member facing inward toward stationary, slide rotating member over guide and onto shaft, using seal pusher tool, until lapped faces of stationary and rotating seal are together. Place spring over shaft and rotating member. Be sure it is seated on the retainer and not cocked or resting on bellows tail.

**Impeller** - Place impeller (18) on motor shaft, with machined step fitting inside the inside diameter of seal spring, by turning clockwise while holding shaft stationary with screwdriver.

**Shredding Ring** - Install shredding ring (27) into volute with the use of an arbor press. Assemble throat (21) into volute (23) with tree allen screws (22).

**Volute** - Lubricate square ring (24) and place in groove in bottom of seal plate (19). Place volute (23) on seal plate (19) being careful not to damage square ring (24). Place nuts (25) with lockwashers (9) onto studs (26) and torque evenly to 11 ft/lbs.

**Cutter** - Screw radial cutter (27) onto shaft, turning it clockwise while holding the shaft stationary with a screwdriver. The radial cutter (27) should be flush with shredding ring (20), on suction side to within  $\pm .020$ . Place washer (28) on screw (29), apply green Loctite on threads and place into shaft and tighten.



**Typical Panel Wiring Schematic**

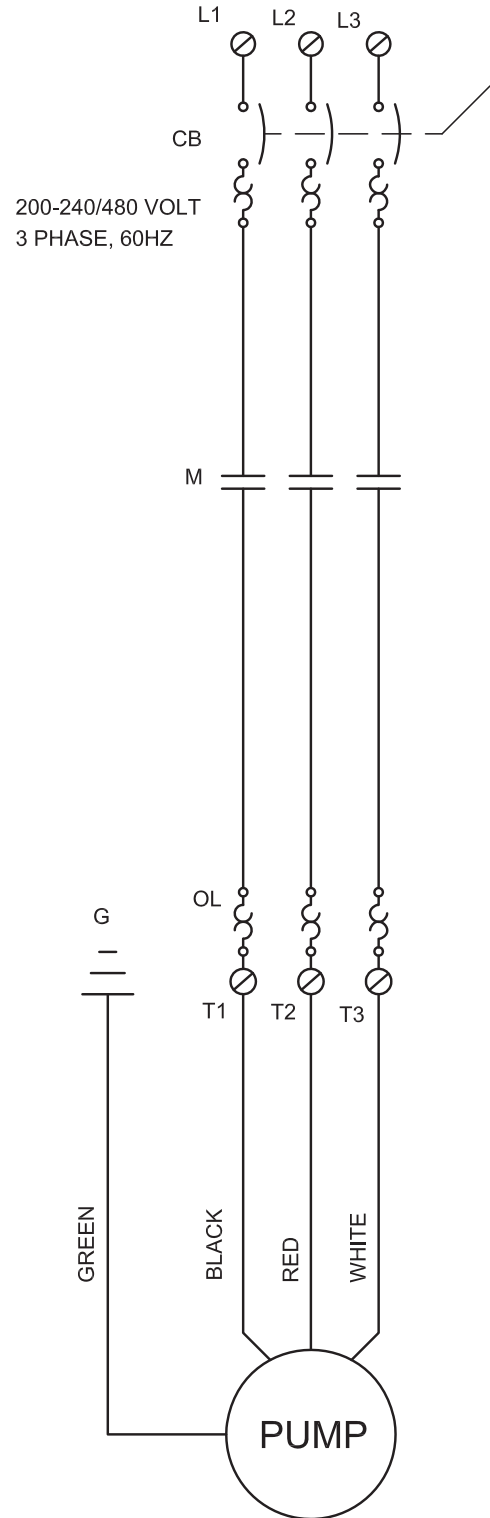
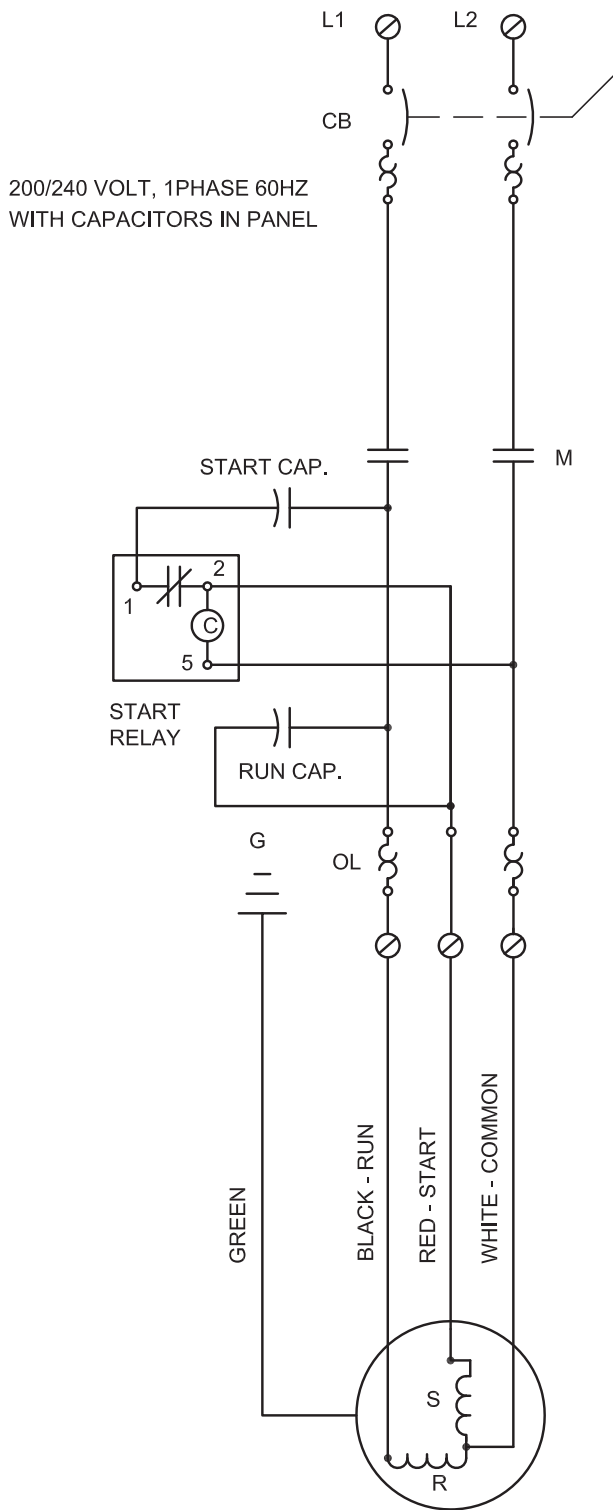

**Figure 6**



Repair Parts

For Repair Part Please supply: Model Number and MFG Date as shown on Name Plate, and Part Description and Part Number as shown on Parts List.

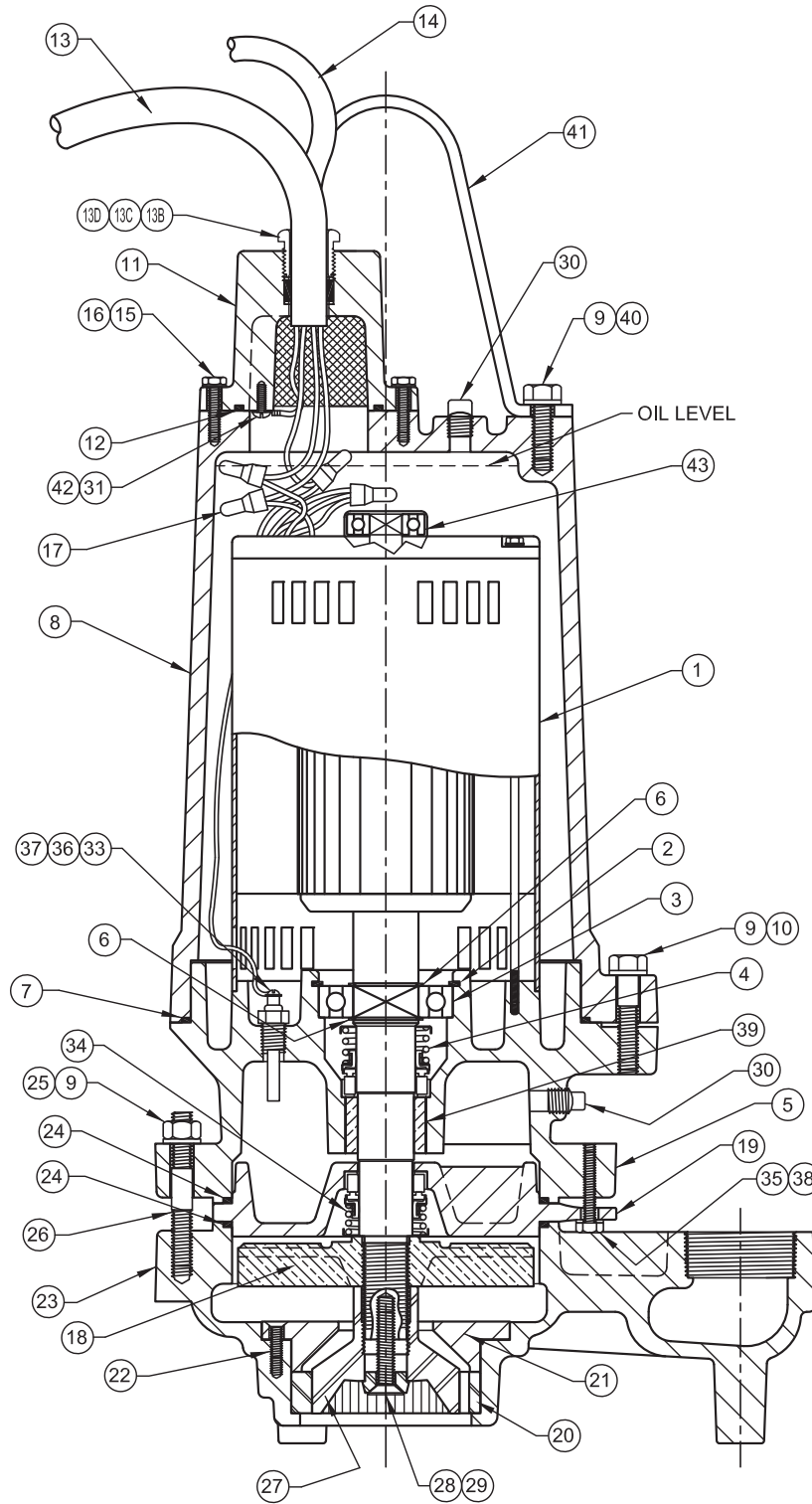

Figure 7



# PF3, 5 & 7.5HP

# Submersible Grinder Pumps

For Repair Part Please supply: Model Number and MFG Date as shown on Name Plate, and Part Description and Part Number as shown on Parts List.

## Repair Parts

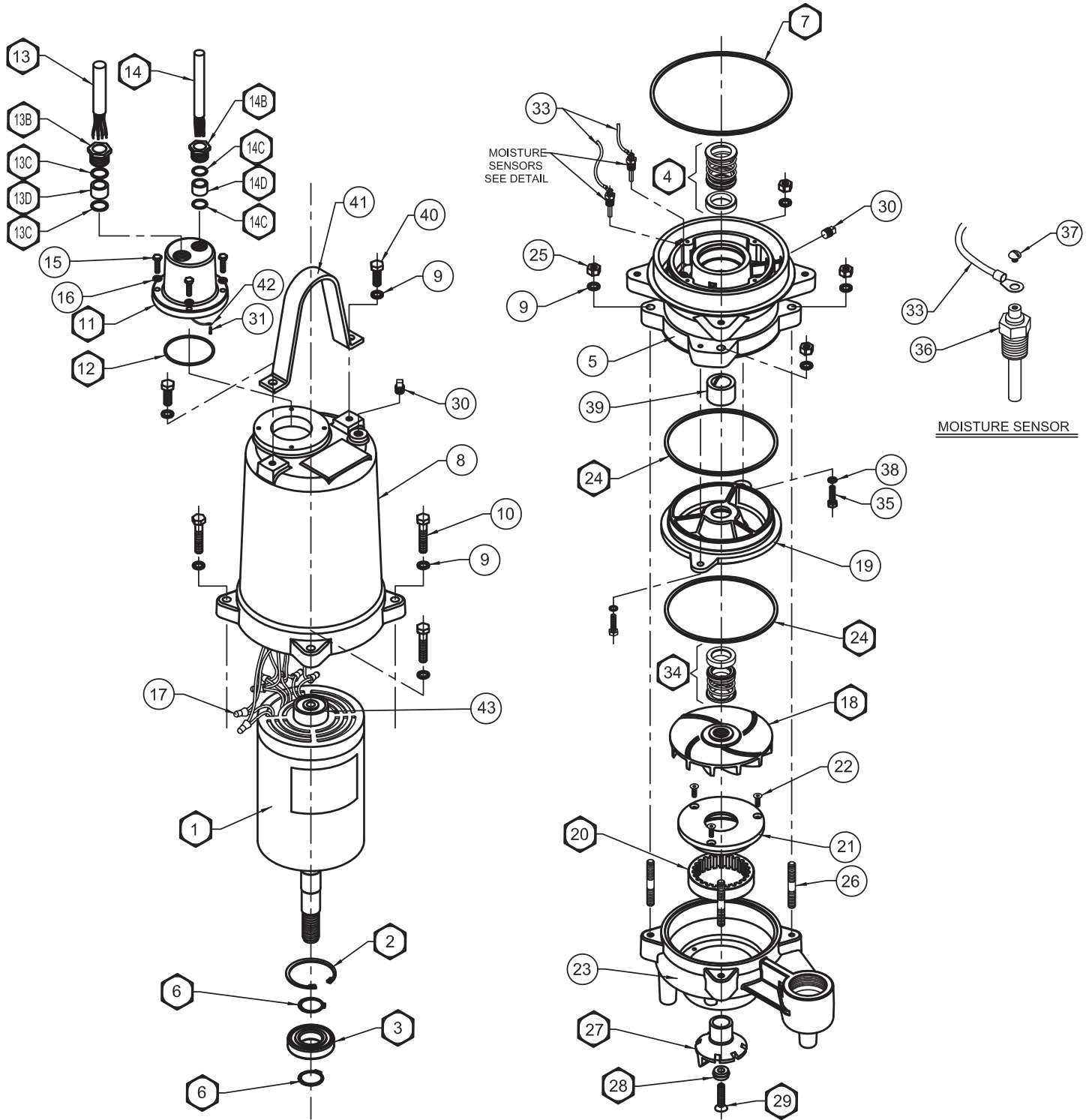

Figure 8



**Repair Parts**

For Repair Part Please supply: Model Number and MFG Date as shown on Name Plate, and Part Description and Part Number as shown on Parts List.

Ref.	Qty		Name	Used On	Part Number
1	1	☆	Motor  (⚡) Do NOT use PF40040054, Replaced by PF40040055, size capacitors accordingly, see page 4.	⚡ 3 HP 230 Volt 1 Ph	⚡ PF40040054
				3 & 5 HP 230 Volt 1 Ph	PF40040055
				3 HP 230/460 Volt 3 Ph	PF40040051
				5 HP 230/460 Volt 3 Ph	PF40040052
				7.5 HP 230/460 Volt 3 Ph	PF40040053
2	2	●	Retaining ring		PF31010004
3	1	●	Ball bearing, lower, 6207ZZC3		PF31020022
4	1	●	Seal, inner C/C/B		PF31030136
5	1		Bearing Housing		PF03040026
6	2	●	Retaining ring		PF31010011
7	1	●	Square ring, 7.25" ID		PF92010087
8	1		Motor housing		PF03100011
9	10		Lockwasher, 7/16 Stainless		◆
10	4		Screw, 7/16-14 x 2.25" Lg., Stainless		◆
11assy	1	☆	Conduit Box & Cable Assembly, 10/4 SOW, 30Ft.		PF067585
11	1	*	Conduit box	Included in Item #11ASSY	PF03100010
12	1	*	O-ring		PF92010063
13	1	*	Power Cable 10/4 SOW		PF31030003
13B	1	*	Hex Plug		PF30400903
13C	2	*	Friction ring		PF91010055
13D	1	*	Grommet		PF92010001
14	1	*	Moisture & Temperture Sensor Cable, 18/5 SOW, 30Ft.		PF31030005
14B	1	*	Hex plug		PF30400901
14C	2	*	Friction ring		PF91010057
14D	1	*	Grommet		PF92010005
15	4		Capscrews, 1/4-20 x 1" Lg., Stainless		◆
16	4		Lockwashers, 1/4" Stainless		◆
17	8		Wire Connectors	Single Phase 230V	PF94010012
	9			Three Phase 230 V	
	11			Three Phase 460V	
18	1	☆	Impeller <b>IMPORTANT:</b> Standard impeller sizes prior to June 2011 were as follows; 7.5HP - A; 6.46; 5HP - B; 6.25; 3HP - C; 5.00		
				5.87" Dia. STD for 7.5HP	PF03140079A
				5.75" Dia. STD for 5HP	PF03140079B
				5.50" Dia.	---
				5.25" Dia.	---
				5.00" Dia.	---
				4.75" Dia.	---
				4.56" Dia. STD for 3 HP	PF03140079C
				4.25" Dia.	---
4.12" Dia.	---				

- ◆ = Acquire standard hardware locally.
- = Cutter Kit
- = Overhaul Kit

- ☆ = Supplied as individual items
- \* = Supplied with item #11 Assy
- = Seal Probe Kit



# PFG 3, 5 & 7.5HP

# Submersible Grinder Pumps

For Repair Part Please supply: Model Number and MFG Date as shown on Name Plate, and Part Description and Part Number as shown on Parts List.

## Repair Parts

19	1		Seal plate		PF03180028
20	1	●○	Shredding ring		PF31010020
21	1		Throat		PF03190021
22	3		Allen Screw, 1/4-20 x .75" Lg, Stainless		◆
23	1		Volute		PF03090083
24	2	●	Square ring, 6.50" ID		PF92010081
25	4		Hex nut, 7/16-14 Stainless		◆
26	4		Stud, 7/16-14 x 3.25" Lg., Stainless		◆
27	1	●○	Radial cutter		PF31030301
28	1	●○	Washer, Stainless		PF30400426
29	1	●○	Screw, 3/8-16 x 1.75" Lg., Stainless		PF91010398
30	2		Pipe plug, 1/4" NPT		◆
31	1	*	Ground screw, 3/16" x 1/2"		◆
32	4¾ qts		Cooling oil, Motor housing		See chart on page 9
	1½ qts		Seal cavity		
33	2	■	Wire Assembly, Moisture Sensor		PF31030011
34	1	●	Seal, outer S/S/V		PF31030137
35	2		Screw, 5/16-18 x 1.25" Lg. Stainless		◆
36	2	■	Moisture Sensor Probe		PF31160001
37	2	■	Machine screw, 6-32 x 1/4" Lg., Stainless	Moisture sensors	◆
38	2		Lockwasher, 5/16" Stainless		◆
39	1		Bearing sleeve		Supplied in item #5
40	2		Screw, 7/16-14 x 1.25" Lg., Stainless		◆
41	1		Lifting bail		PF30400843
42	1	*	Round terminal, 3/16		PF94010043
43	1		Upper Ball Bearing, 6203ZZ		PF070715
<b>Repair Kits</b>					
○	<b>CUTTER KIT</b> - Includes Item numbers: 20, 27, 28, 29				PFGL-CT
●	<b>OVERHAUL KIT</b> - Includes Item numbers: 2, 3, 4, 6, 7, 20, 24, 27, 28, 29, 34				PFGL-OHK
■	<b>SEAL PROBE KIT</b> - Includes item numbers: 33, 36 & 37				PF69775-1

Capacitor Pack for, Other than Power-Flo's control panel:

For units **PRIOR** to Sept. 2010 use, P/N: PF73303 - for PFG3022, 230 volt, 1 phase 3 Hp (See page 11 for wiring schematic).

For units **AFTER** Sept. 2010 use, P/N: PF73305 - for PFG3022, 3HP & PFG5022 5HP, 230 volt, 1 phase (See page 11 for wiring schematic).

Recommended Moisture & Temperature Sensor Relays for control panel, (or equal):

P/N: PF0861 - Warrick relay #IDIEO rated for 25 volt amperes, 115 volt input, 500 volt output (one per pump).

P/N: PF0876 - IDEC relay #RH2BUAC120V (one per pump).

◆ = Acquire standard hardware locally.

○ = Cutter Kit

● = Overhaul Kit

☆ = Supplied as individual items

\* = Supplied with item #11 Assy

■ = Seal Probe Kit

## Typical Name Plate

**POWER-FLO** Pumps & Systems

Model Number

MFG Date

AMPS  VOLTAGE

PHASE  HP

60 Hz

**POWER-FLO** Pumps & Systems  
877-24 PUMPS  
www.powerflopumps.com





**Trouble Shooting Chart**



**Risk of electric shock. Always disconnect the pump from the power source before handling inspections or repairs.**

Symptom	Possible Cause(s)	Corrective Action
Pump will not run	<ol style="list-style-type: none"> <li>1. Poor electrical connection, blown fuse, tripped breaker or other interruption of power; improper power supply</li> <li>2. Motor or switch inoperative (go to manual operation)                             <ol style="list-style-type: none"> <li>2a. Float movement restricted</li> <li>2b. Switch will not activate pump or is defective</li> <li>2c. Defective motor</li> </ol> </li> <li>3. Insufficient liquid level</li> </ol>	<ol style="list-style-type: none"> <li>1. Check all electrical connections for security. Have electrician measure current in motor leads, if current is within <math>\pm 20\%</math> of locked rotor Amps, impeller is probably locked. If current is 0, overload may be tripped. Remove power, allow pump to cool, then re-check current.</li> <li>2a. Reposition pump or clean basin as required to provide adequate clearance for float</li> <li>2b. Disconnect level control. Set ohmmeter for a low range, such as 100 ohms full scale and connect to level control leads. Actuate level control manually and check to see that ohmmeter shows zero ohms for closed switch and full scale for open switch. (Float Switch)</li> </ol>
Pump will not turn off	<ol style="list-style-type: none"> <li>2a. Float movement restricted</li> <li>2b. Switch will not activate pump or is defective</li> <li>4. Excessive inflow or pump not properly sized for application</li> <li>9. Pump may be air locked causing pump not to flow</li> <li>14. H-O-A switch on panel is in "HAND" position</li> </ol>	<ol style="list-style-type: none"> <li>2c. Check winding insulation (Megger Test) and winding resistance. If check is outside of range, dry and re-check. If still defective, replace per service instructions.</li> <li>3. Make sure liquid level is above the pump</li> <li>4. Re-check all sizing calculations to determine proper pump size.</li> </ol>
Pump hums but doesn't run	<ol style="list-style-type: none"> <li>1. Incorrect low voltage</li> <li>8. Impeller jammed or loose on shaft, or inlet plugged</li> </ol>	<ol style="list-style-type: none"> <li>5. Check discharge line for restrictions, including ice if line passes through or into cold areas.</li> <li>6. Remove and examine check valve for proper installation and freedom of operation</li> <li>7. Open valve</li> <li>8. Check impeller for freedom of operation, security and condition. Clean impeller cavity and inlet of any obstruction</li> </ol>
Pump delivers insufficient capacity	<ol style="list-style-type: none"> <li>1. Incorrect low voltage</li> <li>4. Excessive inflow or pump not properly sized for application</li> <li>5. Discharge restricted</li> <li>6. Check valve partially closed or installed backwards</li> <li>7. Shut-off valve closed</li> <li>8. Impeller jammed or loose on shaft, or inlet plugged</li> <li>9. Pump may be air locked causing pump not to flow</li> <li>10. Pump running backwards</li> </ol>	<ol style="list-style-type: none"> <li>9. Loosen union slightly to allow trapped air to escape. Verify that turn-off level of switch is set so that the suction is always flooded. Clean vent hole</li> <li>10. Check rotation. If power supply is three phase, reverse any two of three power supply leads to ensure proper impeller rotation</li> <li>11. Repair fixtures as required to eliminate leakage</li> <li>12. Check pump temperature limits and fluid temperature</li> <li>13. Replace portion of discharge pipe with flexible connector or tighten existing piping.</li> </ol>
Pump cycles too frequently or runs periodically when fixtures are not in use	<ol style="list-style-type: none"> <li>6. Check valve partially closed or installed backwards</li> <li>11. Fixtures are leaking</li> <li>15. Ground water entering basin</li> </ol>	<ol style="list-style-type: none"> <li>14. Turn to automatic position</li> <li>15. Check for leaks around basin inlet and outlets</li> </ol>
Pump shuts off and turns on independent of switch, (trips thermal overload protector). <b>CAUTION!</b> Pump may start unexpectedly. Disconnect power supply.	<ol style="list-style-type: none"> <li>1. Incorrect low voltage</li> <li>4. Excessive inflow or pump not properly sized for application</li> <li>8. Impeller jammed or loose on shaft, or inlet plugged</li> <li>12. Excessive water temperature (internal protection only)</li> </ol>	
Pump operates noisily or vibrates excessively	<ol style="list-style-type: none"> <li>2c. Worn bearings, motor shaft bent</li> <li>5. Debris in impeller cavity or broken impeller</li> <li>10. Pump running backwards</li> <li>13. Piping attachments to building structure too loose or rigid</li> </ol>	

**NOTE:** Power-Flo Pumps & Systems assumes no responsibility for damage or injury due to disassembly in the field. Disassembly of the pumps or supplied accessories other than at Power-Flo Pumps & Systems or its authorized service centers, automatically voids warranty.



**LIMITED WARRANTY**

Manufacturer warrants, to the immediate purchaser and subsequent initial owner during the warranty period, every new pump to be free from defects in material and workmanship under normal use and service, when properly used and maintained, for a period of eighteen (18) months from date of manufacture or twelve (12) months from date of installation (which ever comes first). Failure due to wear due to excessive abrasives is not covered. The initial owner is the purchaser who first uses the pump after its initial installation, or for non-permanent installation, the first owner who uses the pump. The date of installation shall be determined by a dated sales receipt noting the model and serial number of the pump. The dated sales receipt must accompany the returned pump. Product will be repaired, replaced or remanufactured at Manufacturer's option. No allowance will be made for shipping charges, damages, labor or other charges that may occur due to product failure, repair or replacement. This warranty does not apply to and there shall be no warranty for any material or product that has been disassembled without prior approval of Manufacturer, subjected to misuse, misapplication, neglect, alteration, accident or act of God; that has not been installed, operated or maintained in accordance with Manufacturer's installation instructions; that has been exposed to outside substances including but not limited to the following: sand, gravel, cement, mud, tar, hydrocarbons, hydrocarbon derivatives (oil, gasoline, solvents, etc.), or other abrasive or corrosive substances, wash towels or feminine sanitary products, etc. in all pumping applications. The warranty set out in the paragraph above is in lieu of all other warranties expressed or implied; and we do not authorize any representative or other person to assume for us any other liability in connection with our products. Contact Manufacturer at: 1-877-24PUMPS or [www.powerflopumps.com](http://www.powerflopumps.com), Attention: Customer Service Department, to obtain any needed repair or replacement of part(s) or additional information pertaining to our warranty.

**MANUFACTURER EXPRESSLY DISCLAIMS LIABILITY FOR SPECIAL, CONSEQUENTIAL OR INCIDENTAL DAMAGES OR BREACH OF EXPRESSED OR IMPLIED WARRANTY; AND ANY IMPLIED WARRANTY OF FITNESS FOR A PARTICULAR PURPOSE AND OF MERCHANTABILITY SHALL BE LIMITED TO THE DURATION OF THE EXPRESSED WARRANTY.**

Some states do not allow limitations on the duration of an implied warranty, so the above limitation may not apply to you. Some states do not allow the exclusion or limitation of incidental or consequential damages, so the above limitation or exclusion may not apply to you. This warranty gives you specific legal rights and you may also have other rights which vary from state to state.

