

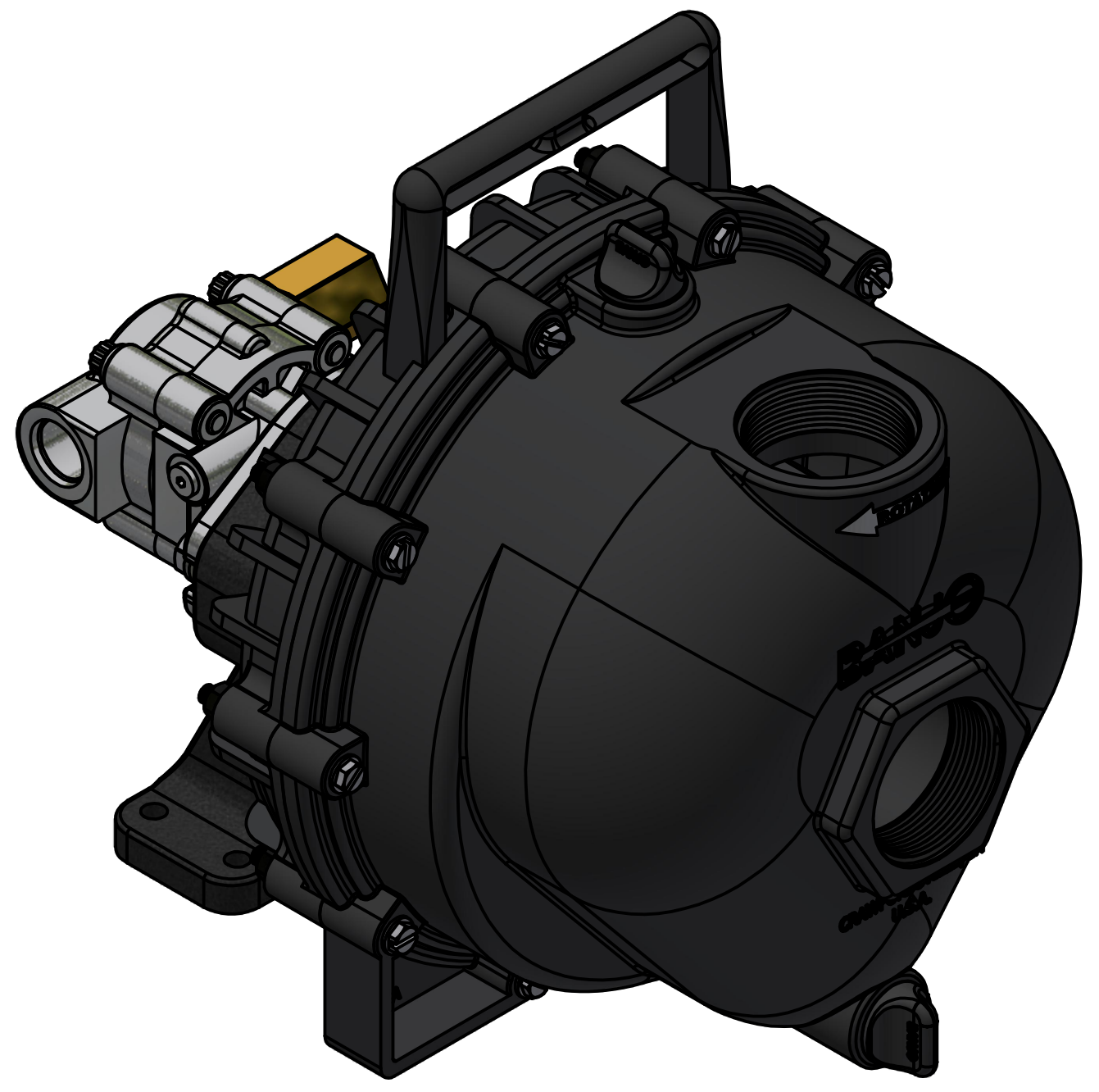

PARTS LIST			
ITEM	QTY	PART NUMBER	DESCRIPTION
1	1	12049F	HYD. MOTOR PEDESTAL
2	1	12055E	HYD. ADAPTER SHAFT
3	1	12702A	2" POLY PUMP VOLUTE
4	1	12703A	POLY PUMP REAR BRACKET
5	1	12705	PUMP CHECKVALVE, EPDM
6	1	12712A	2" POLY PUMP BODY
6-1	2	12777	1/2" DRAIN PLUG
6-2	2	UV15163	AS568A -114 O-RING, EPDM, BLACK
6-3	1	X12712A	2" POLY PUMP BODY
7	4	12715A	5/16-24 X 1 3/4" HHCS WITH TORQ-PATCH
8	4	12717	AS568A -011 O-RING, EPDM
9	1	12719A	AS568A -375 O-RING, EPDM, BLACK
10	10	12720	1/4-20 X 2 1/2" SL IND HEX WASHER HEAD SCREW
11	2	12725	#6 X 1/2" PPH SMS
12	1	12733	MECHANICAL SEAL ASSEMBLY, EPDM, BULK PACKED
13	1	12754	O'RING SEGMENT
14	1	12765A	5/16-24 X 1 1/8" HFS
15	1	12772	POLY 5 VANE IMPELLER
16	1	12775A	7/16-14 HEX NUT
17	1	12900	#10 X 1 1/2" PPH SMS
18	4	12901	5/16" FLAT WASHER
19	1	12902A	3/16" SQ. X 5/8" KEY
20	1	12910	DECAL (N/S)
21	1	15752	IMPELLER SHIM
22	1	17056E	3206 BEARING
23	2	18010SS	3/8-16 X 1 1/8" HHCS
24	1	A204	AS568A -204 O-RING, EPDM, BLACK
26	1	HY10131	MGG20025BC1D3 GRESEN HYD MTR
27	1	HY10132	HYD. CHECK VALVE
29	10	V07018	1/4" LOCKWASHER
30	10	V07019	1/4"-20 S.S. HEX NUT
31	2	V20018	3/8" LOCKWASHER



THIS DRAWING AND ALL INFORMATION CONTAINED THEREON ARE THE EXCLUSIVE PROPERTY OF BANJO CORPORATION.

UNLESS SPECIFICALLY NOTED, THIS DRAWING AND ITEMS SHOWN ON THIS DRAWING ARE SUBJECT TO CHANGE AT ANY TIME.



BANJO CORPORATION
 150 BANJO DRIVE, CRAWFORDSVILLE, IN 47933
 WEB SITE: WWW.BANJO.CORP.COM
 E-MAIL: BANJOSALES@IDEXCORP.COM

DESCRIPTION
2" POLY PUMP W/ HYD. MOTOR

PART NUMBER
200PHY