

Parts List			
ITEM	QTY	PART NUMBER	DESCRIPTION
1	1	12777	1/2" DRAIN PLUG
2	4	12901	5/16" FLAT WASHER
3	1	17018	PUMP ADAPTER GASKET
4	1	17033	Z-RAIL (PAIR)
5	4	17034	5/16-18 X 1-1/2" HHCS
6	4	17040	5/16-24 X 1" HHCS
7	1	17123	CI PUMP KEYED CLAMP
8	1	17135	MECH. SEAL ASSY.
9	1	200XPOIL	2" CI PUMP SUB-ASSEMBLY
9-1	1	15022	2" PUMP HANDLE
9-2	1	17004	GAS ENGINE ADAPTER
9-3	1	17006	ADAPTER SHAFT
9-4	1	17008	PUMP IMPELLER
9-5	1	17009B	5/8-18 IMPELLER NUT
9-6	1	17010	1/2-13 HEX NUT
9-7	1	17126	2" PUMP HOUSING ASSY
9-8	6	V10118	5/16" LOCKWASHER
9-9	6	V10119	5/16"-18 SS NUT
10	1	E5H	5.5 HP HONDA GX160
11	1	UV15163	AS568A -114 O-RING, EPDM, BLACK
12	8	V10118	5/16" LOCKWASHER
13	4	V10119	5/16"-18 SS NUT

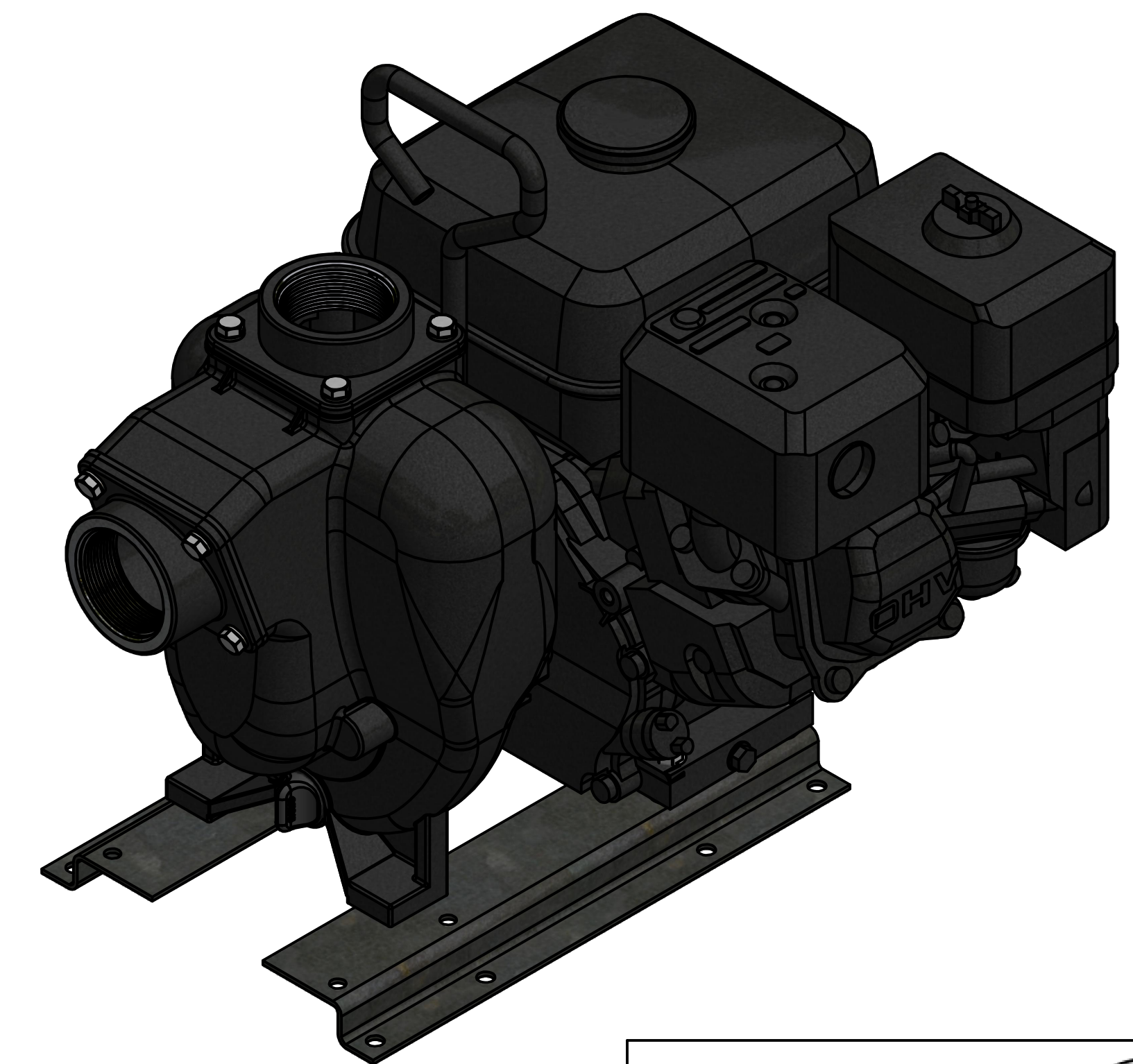
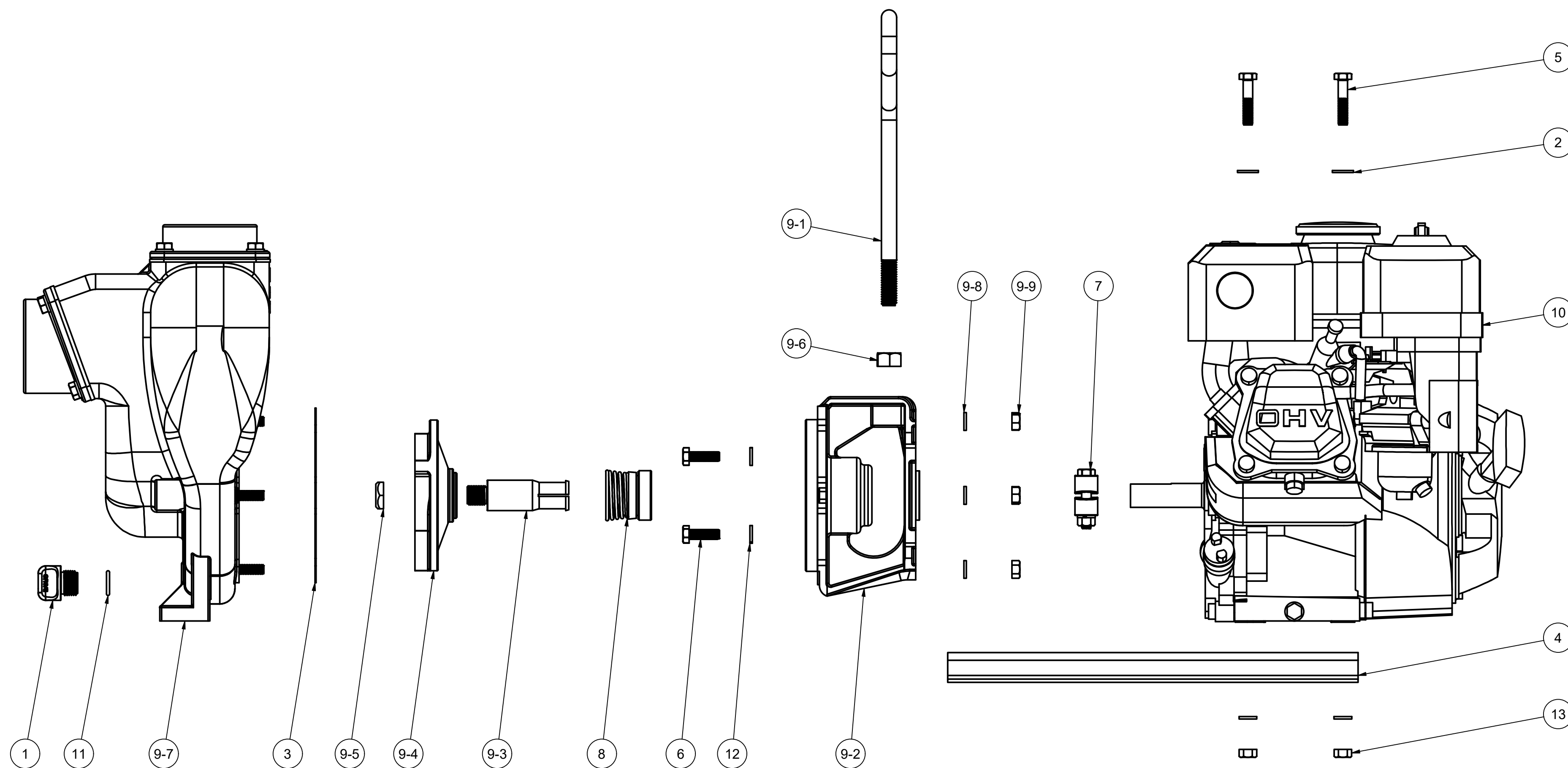

THIS DRAWING AND ALL INFORMATION CONTAINED THEREON ARE THE EXCLUSIVE PROPERTY OF BANJO CORPORATION.

UNLESS SPECIFICALLY NOTED, THIS DRAWING AND ITEMS SHOWN ON THIS DRAWING ARE SUBJECT TO CHANGE AT ANY TIME.

BANJO CORPORATION
 150 BANJO DRIVE, CRAWFORDSVILLE, IN 47933
 WEB SITE: WWW.BANJO.CORP.COM
 E-MAIL: BANJOSALES@DEXCORP.COM

DESCRIPTION
2" CENT CI PUMP w/ 5HP HONDA MOTOR

PART NUMBER
200PIH-5