

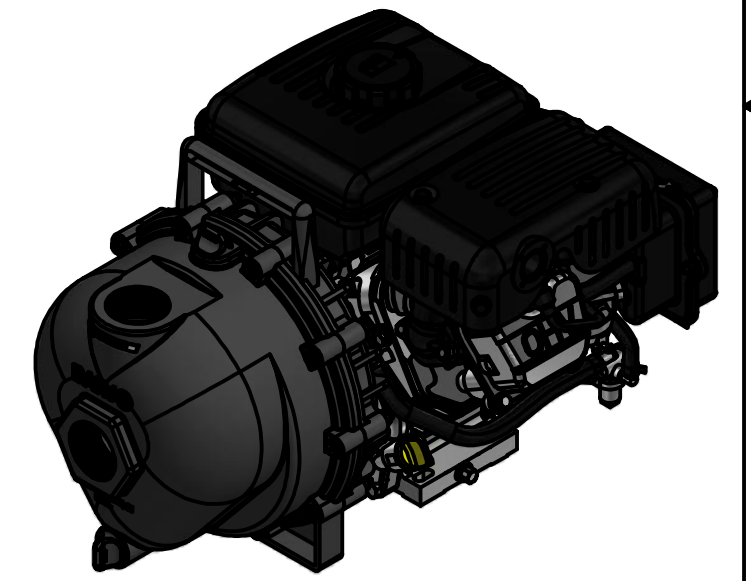

Parts List			
ITEM	QTY	PART NUMBER	DESCRIPTION
1	1	12702A	2" POLY PUMP VOLUTE
2	1	12703A	POLY PUMP REAR BRACKET
3	1	12705	PUMP CHECKVALVE, EPDM
4	1	12706	PUMP SLINGER
5	1	12711AP	1-1/2" PUMP BODY ASSEMBLY
6	4	12715A	5/16-24 X 1 3/4" HHCS WITH TORQ-PATCH
7	4	12717	#11 O'RING, EPDM
8	1	12719A	#375 O'RING, EPDM
9	10	12720	1/4-20 X 2 1/2" SL IND HWHS
10	2	12725	#6 X 1/2" PPH SMS
11	1	12733	MECHANICAL SEAL ASSY
12	1	12754	O'RING SEGMENT
13	1	12765A	5/16-24 X 1 1/8" HFS
14	1	12771A	IMPELLER
15	1	12775A	7/16-14 HEX NUT
16	1	12900	#10 X 1 1/2" PPH SMS
17	4	12901	5/16" FLAT WASHER
18	1	12902A	3/16" SQ. X 5/8" KEY
19	1	12910	DECAL (N/S)
20	1	A204	#204 O'RING, EPDM
21	10	D02520LF	1/4"-20 SS Nylon Insert Locknut
22	1	E3	3.5 HP B&S

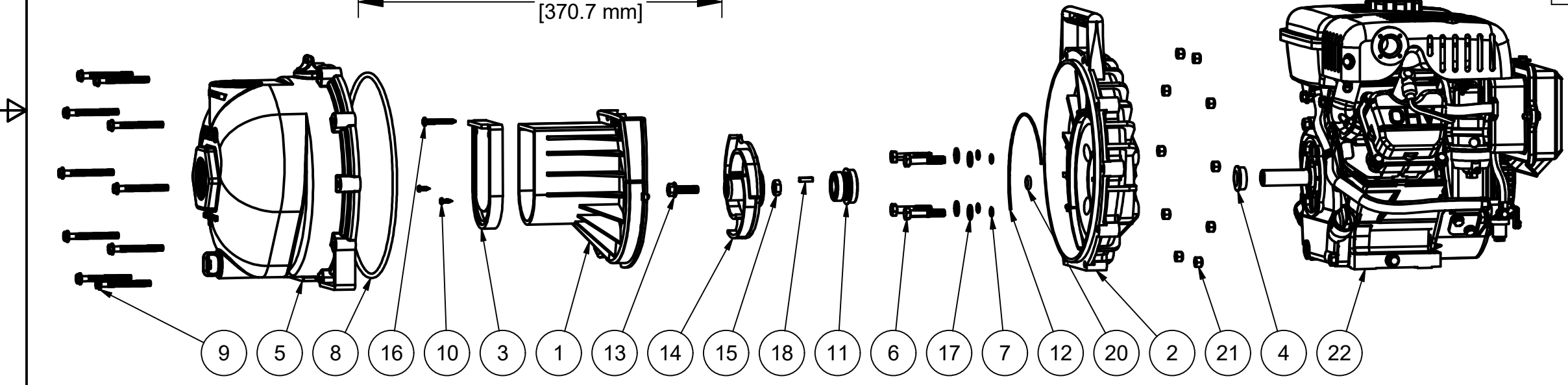

THIS DRAWING AND ALL INFORMATION CONTAINED THEREON ARE THE EXCLUSIVE PROPERTY OF BANJO CORPORATION.

UNLESS SPECIFICALLY NOTED, THIS DRAWING AND ITEMS SHOWN ON THIS DRAWING ARE SUBJECT TO CHANGE AT ANY TIME.



BANJO CORPORATION

150 BANJO DRIVE, CRAWFORDSVILLE, IN 47933
 WEB SITE: WWW.BANJOCORP.COM
 E-MAIL: BANJOSALES@IDEXCORP.COM

DESCRIPTION
1 1/2" POLY-PUMP 3.5 HP B&S

PART NUMBER
150P-3