

Parts List			
ITEM	QTY	PART NUMBER	DESCRIPTION
1	1	12155	ADAPTER SHAFT
2	1	12202W	2" POLY RESERVOIR
3	1	12705	PUMP CHECKVALVE, EPDM
4	1	12707W	2" W.S. REAR BRACKET
5	4	12709	#13 O-RING, EPDM
6	4	12717	#11 O-RING, EPDM
7	1	12719A	#375 O-RING, EPDM
8	10	12720	1/4-20 X 2 1/2" SL IND HWHS
9	2	12725	#6 X 1/2" PPH SMS
10	1	12754	O-RING SEGMENT
11	1	12766	5/16-24 X 3 1/4" HFS
12	1	12775A	7/16-14 HEX NUT
13	2	12777	1/2" DRAIN PLUG
14	1	12882A	BEARING PEDESTAL
15	1	12900	#10 X 1 1/2" PPH SMS
16	5	12901	5/16" FLAT WASHER
17	2	12902A	3/16" SQ. X 5/8" KEY
18	1	12910	DECAL (N/S)
19	4	13034	5/16-24 X 3 1/2" HHCS
20	1	13702	3" POLY PUMP VOLUTE
21	1	13712	3" POLY PUMP BODY ASSY.
22	1	13719	#256 O-RING, EPDM
23	1	13772	3" POLY PUMP IMPELLER
24	1	15035E	SEAL ASSY.
25	1	A204	#204 O-RING, EPDM
26	1	CV10175	ADAPTER GASKET
27	1	KK-57	WET SEAL WARNING TAG (N/S)
28	2	UV15163	#114 O-RING, EPDM
29	10	V07018	1/4" LOCKWASHER
30	10	V07019	1/4-20 HEX NUT

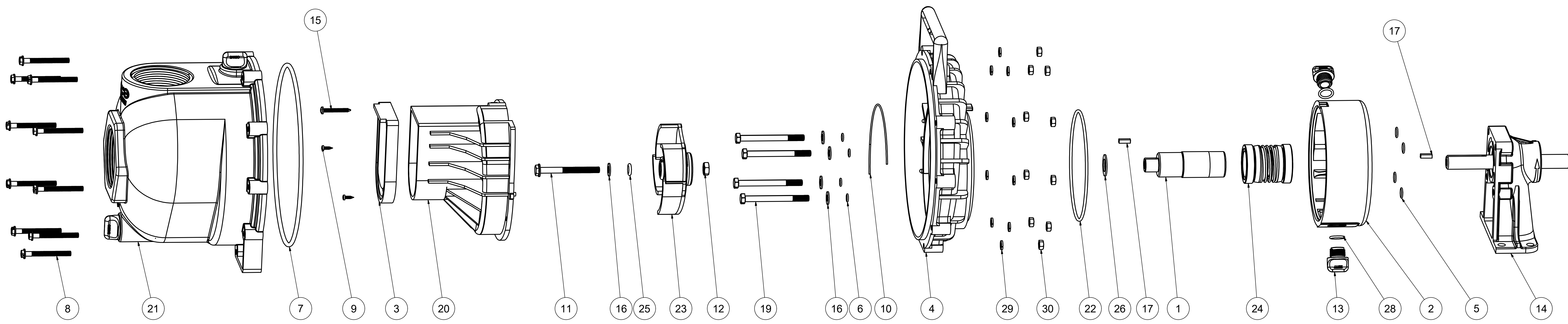

THIS DRAWING AND ALL INFORMATION CONTAINED THEREON ARE THE EXCLUSIVE PROPERTY OF BANJO CORPORATION.

UNLESS SPECIFICALLY NOTED, THIS DRAWING AND ITEMS SHOWN ON THIS DRAWING ARE SUBJECT TO CHANGE AT ANY TIME.

BANJO CORPORATION
 150 BANJO DRIVE, CRAWFORDSVILLE, IN 47933
 WEB SITE: WWW.BANJOCORP.COM
 E-MAIL: SALES1@BANJOCORP.COM

DESCRIPTION
3" POLY WET SEAL PUMP W/ BEARING PEDESTAL

PART NUMBER
300PBW