

INSTRUCTION MANUAL

FOR INSTALLATION AND OPERATION
MANUAL.

OUR REF: 54038

ITEM:

Excel® XR Series Electronic Metering Pump



This manual should be made available to the person responsible for installation, operation and maintenance.

THIS PAGE INTENTIONALLY LEFT BLANK

MILTON ROY GLOBAL SERVICES

Partners in your Process

Welcome to the Milton Roy family

Our dedicated teams across the globe work non-stop to ensure your pumps and mixers perform to the highest standard every day.

WE ARE AT YOUR SERVICE



OEM SPARE PARTS

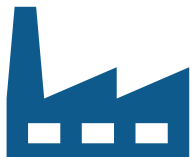

FIELD SERVICE



REPAIR



SITE AUDIT



TRAINING



TECHNICAL
SUPPORT



MAINTENANCE



After-Market Services

Europe/Africa: +33 (0)2.32.68.30.02 Middle-East: +971-565441901

mr14.sat@miltonroy.com

10 Grande Rue - 27360 Pont-Saint Pierre - FRANCE

www.miltonroy.com



PRECAUTIONS

The following precautions should be taken when working with LMI metering pumps. Please read this section carefully prior to installation.

Protective Clothing



ALWAYS wear protective clothing, face shield, safety glasses and gloves when working on or near your metering pump. Additional precautions should be taken depending on the solution being pumped. Refer to Safety Data Sheets (SDS) precautions from your solution supplier.

Water Pre-Prime



All LMI pumps are pre-primed with water when shipped from the factory. If your solution is not compatible with water, disassemble the Pump Head Assembly. Thoroughly dry the pump head, valves, O-rings, balls and diaphragm. Reassemble head assembly tightening screws in a crisscross pattern. Refill the pump head with the solution to be pumped before priming the pump. (This will aid in priming.)

Liquid Compatibility



CAUTION: The evaluation performed by ETL was tested with water only. The pumps are certified to NSF 61 with: sodium hypochlorite (12.5%), sulfuric acid (98.5%), sodium hydroxide (50%), and hydrochloric acid (30%). Determine if the materials of construction included in the liquid handling portion of your pump are adequate for the solution (chemical) to be pumped. Always refer to the solution supplier and the LMI Chemical Resistance Chart for compatibility of your specific LMI metering pump. Contact your local LMI distributor for further information.

Tubing Connections



Inlet and outlet tubing or pipe sizes must not be reduced. Outlet tubing size must not be increased. Make certain that all tubing is SECURELY ATTACHED to fittings prior to start-up (see section 3.3 Tubing Connections). ALWAYS use LMI supplied tubing with your pump, as the tubing is specifically designed for use with the pump fittings. It is recommended that all tubing be shielded and secure to prevent possible injury in case of rupture or accidental damage. If tubing is exposed to sunlight, black UV resistant tubing should be installed. Check tubing frequently for cracks and replace as necessary.

Fittings and Machine Threads



All fittings should be hand-tightened. An additional 1/8 - 1/4 turn after the fitting is snug may be necessary to provide a leak-proof seal. Excessive overtightening or use of a pipe wrench can cause damage to the fittings, seals, or pump head.

Most LMI pumps have straight screw machine threads on the head and fittings and are sealed by the O-rings. DO NOT use PTFE tape or pipe dope to seal these threads. PTFE Tape may only be used on NPT threads.

Plumbing



Always adhere to your local plumbing codes and requirements. Be sure installation does not constitute a cross connection. Check local plumbing codes for guidelines. LMI is not responsible for improper installations.

Back Pressure/Anti-Syphon Valve



If you are pumping downhill or into low or no system pressure, a backpressure /anti-syphon device should be installed to prevent over pumping or syphoning. Contact your LMI distributor for further information.

Electrical Connections



WARNING: To reduce the risk of electrical shock, the metering pump must be plugged into a properly grounded grounding-type receptacle with ratings conforming to the data on the pump control panel. The pump must be connected to a good ground. Do not use adapters! All wiring must conform to local electrical codes. If the supply cord is damaged, it must be replaced by the manufacturer, stocking distributor, or authorized repair center in order to avoid a hazard.

Fuse and Battery



CAUTION: Battery may explode if mistreated. Do not recharge, disassemble or dispose of in fire. The battery and fuse are internal, factory serviceable parts, and must be replaced by the factory or a qualified distributor with parts of the same type and rating.

Flooding



WARNING: Install this pump in a location where flooding cannot occur.

Ground Fault Circuit Interrupter



WARNING: To reduce the risk of electric shock, install only on a circuit protected by a Ground Fault Circuit Interrupter (GFCI).

Line Depressurization



To reduce the risk of chemical splash during disassembly or maintenance, all installations should be equipped with line depressurization capability.

Over Pressure Protection



To ensure safe operation of the pump it is recommended that some type of safety / pressure-relief valve be installed to protect the piping and other system components from failing due to excessive pressure.

Chemical Concentration



There is a potential for elevated chemical concentration during periods of no flow, for example, during backwash in the system. Steps, such as turning the pump off, should be taken during operation or installation to prevent this.
See your distributor about other external control options to help mitigate this risk.

Retightening Components



Plastic materials will typically exhibit creep characteristics when under pressure over a period of time and to insure a proper fit it may be necessary to retighten the head bolts periodically. To insure proper operation, we recommend tightening the bolts to 25 inch-pounds after the first week of operation and on a monthly basis thereafter.

Flow Display



The accuracy of the flow value as shown on the pump display is highly dependent on the specific application. Calibration is necessary in order to display an accurate measure of the flow.

Spills



CAUTION: Spills of Dangerous chemicals should be cleaned up immediately.



SECTION 1 - INTRODUCTION 8

 1.1 Introduction 8

 1.2 Specifications 8

SECTION 2 - UNPACKING CHECK LIST 9

 2.1 Unpacking Check List 9

SECTION 3 - INSTALLATION 10

 3.1 Pump Location and Installation 10

 3.2 Pump Mounting 10

 3.2.1 Flooded Suction 11

 3.3 Tubing Connections 12

 3.4 Foot Valve / Suction Tubing Installation 14

 3.5 Injection Check Valve and Discharge Tubing Installation 15

SECTION 4 - OPERATION 16

 4.1 Controls, Inputs and Outputs 16

 4.2 Display Screen and Keypad 16

 4.2.1 Pump Start / Stop 17

 4.2.2 Full Capacity Operation 17

 4.2.3 Multi-Function Buttons 17

 4.2.4 Notification Bar 17

 4.2.5 Display Navigation 18

 4.2.6 Icons 18

 4.3 Manual Mode 18

 4.4 Settings 19

 4.4.1 Prime Settings 19

 4.4.2 Firmware Information 19

 4.4.3 Calibration 19

 4.4.4 Time / Day 19

 4.4.5 Alarm Log 19

 4.4.6 Keypad Lock Functions 20

 4.4.7 Set Liquid Measure Units 20

 4.4.8 LCD Brightness 21

 4.4.9 Reload Factory Defaults 21

 4.4.10 Power Loss Options 21

 4.4.11 Totalizer 22

 4.4.12 Change Language 22

 4.4.13 StayPrime™ Degassing Technology 22

 4.4.14 Slow Mode 23

 4.4.15 Configure Input 23

 4.5 Start-Up / Priming 25

 4.6 Calibration 26

SECTION 5 - SPARE PARTS REPLACEMENT AND ROUTINE MAINTENANCE 31

 5.1 DEPRESSURIZING THE DISCHARGE LINE 16

 5.2 DIAPHRAGM REPLACEMENT 16

 5.3 CARTRIDGE VALVE AND O-RING REPLACEMENT 16

 5.4 INJECTION CHECK VALVE PARTS REPLACEMENT 16

SECTION 6 - TROUBLESHOOTING GUIDE 22



LIST OF ILLUSTRATIONS

FIGURE 1. Flooded Suction Pump Mount	11
FIGURE 2. Ferrule Assembly	13
FIGURE 3. Foot Valve / Suction Tubing Installation	14
FIGURE 4. Typical Injection Check Valve Installation	15
FIGURE 5. Notification Bar	17
FIGURE 6. Settings	18
FIGURE 7. Home Screen	18
FIGURE 8. Settings	19
FIGURE 9. Firmware Rev.	19
FIGURE 10. Time / Day	19
FIGURE 11. Lock Password	20
FIGURE 12. Password Entry Block	20
FIGURE 13. Set Unit	20
FIGURE 14. LCD Brightness	21
FIGURE 15. Factory Default	21
FIGURE 16. Factory Default Reset Verification	21
FIGURE 17. Power Loss Options	21
FIGURE 18. Totalizer	22
FIGURE 19. Change Language	22
FIGURE 20. Slow Mode Settings	23
FIGURE 21. Configure Input	23
FIGURE 22. Input Diagram	24
FIGURE 23. Pin Diagram	24
FIGURE 24. Prime Settings	25
FIGURE 25. Pump Calibration (Set Flow Rate)	26
FIGURE 26. Pump Calibration (Start Flow)	26
FIGURE 27. Graduated Cylinder	27
FIGURE 28. Pump Calibration	27
FIGURE 29. Pump Assembly	28
FIGURE 30. Diaphragm Replacement (Full Out)	29
FIGURE 31. Diaphragm Replacement (Full In)	29
FIGURE 32. Injection Check Valve Assembly	30

SECTION 1 - INTRODUCTION

1.1 Introduction

LMI's metering pumps deliver the highest level of repetitive accuracy and reliability with the capability to pump a wide range of chemicals. Our comprehensive selection of pumps means you get the right pump for the right application. Every one of our pumps is engineered to exceed expectations and is backed by a global network of highly trained field engineers and aftersales support.

Please review this manual carefully. Pay particular attention to warnings and precautions. Always follow good safety procedures, including the use of proper clothing, eye and face protection.

1.2 Specifications

Ingress protection	IP65 / NEMA 4X
Voltage / Frequency	100-240 V / 50-60 Hz
Max. Current / Wattage	XRD - 0.60 A / 60 W XRE - 1.20 A / 100 W
Operation environment	Indoor / Outdoor
Process fluid temperature	-10 °C to +40 °C
Operating ambient temperature	-10 °C to +40 °C
Storage temperature	-40 °C to +70 °C
Operating humidity range:	0-95 % RH (Non-condensing)
Repeatability accuracy	+/- 1 %
Turndown	1000:1 (200:1 PTFE-Seat, 500:1 FKM-Seat)

Table 1: General Specifications

Output Code	Max. Flow ⁽¹⁾		Max. Press		Stroke Length	Max. Stroke Speed	Max. Viscosity			Max. Suction Lift		Max. Suction Inlet Pressure		Min. Pressure Differential (Suction to Discharge)		
							Standard Liquid Ends	High Viscosity Liquid Ends								
-	[GPH]	[l/h]	[psi]	[bar]	[mm]	[SPM]		Polymer	Other Products	[cP]	[ft]	[m]	[psi]	[bar]	[psi]	[bar]
2	5.6	21.2	175 ⁽²⁾⁽³⁾	12 ⁽²⁾⁽³⁾	3	151	50	1250	250		13.1	4	30	2	30	2
3	14.0	53.0	75	5	6	162	50	1250	250		13.1	4	30	2	30	2
4	18.0	68.1	50	3.5	3	144	50	1250	250		6.5	2	30	2	30	2

Table 2a: XRD Liquid End Specifications

Output Code	Max. Flow ⁽¹⁾		Max. Press		Stroke Length	Max. Stroke Speed	Max. Viscosity				Max. Suction Lift		Max. Suction Inlet Pressure		Min. Pressure Differential (Suction to Discharge)			
							Standard Liquid Ends	High Viscosity Liquid Ends										
-	[GPH]	[l/h]	[psi]	[bar]	[mm]	[SPM]		Polymer	w/o SLOW MODE	SLOW MODE 20%	SLOW MODE 50%	[cP]	[ft]	[m]	[psi]	[bar]	[psi]	[bar]
2	16	60.6	150	10.3	6	198	50	2000	1000	3000	2000		13.1	2	30	2	30	2
3	32	121.1	100	6.9	3.6	200	50	2000	500*	2000	500*		6.5	2	30	2	30	2
4	53	200.6	60	4.1	6	184	50	2000	500*	2000	1000		6.5	2	30	2	30	2

Table 2b: XRE Liquid End Specifications

- (1) Maximum flow rate at maximum pressure. Maximum flow rate may be higher at lower pressures.
- (2) 175 psi (12 bar) max. with 1/4" x 1/2" reinforced PVC hose or 6 x 12mm reinforced PVC hose; 150 psi (10 bar) max. with 3/8" PE tube or 8mm PE tube.
- (3) High viscosity option 150 psi (10.3 bar).

* Up to 20% flow reduction.

SECTION 2 - UNPACKING CHECK LIST

2.1 Unpacking Check List

Your carton will contain many or all of the following items. Please notify the carrier immediately if there are any signs of damage to the pump or its parts.



Metering Pump



Foot Valve

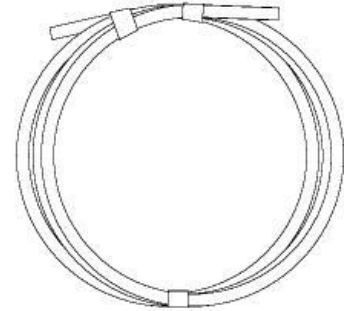

Tubing (0 or 2 Rolls)



Ceramic Foot Valve Weight



Injection Check Valve



**External Control Cable
(5 Pin or 4 Pin Cable)**



Tube Connection Hardware

SECTION 3 - INSTALLATION

3.1 Pump Location and Installation

Locate pump in an area convenient to solution tank and electrical supply.

The pump should be accessible for routine maintenance, and should not be operated in ambient temperatures above 104°F (40°C). If the pump will be exposed to direct sunlight, LMI black, UV resistant tubing should be installed.

3.2 Pump Mounting

The pump can be mounted in one of two ways:

- ◆ **Flooded Suction** (ideal installation); or
- ◆ **Suction Lift** – when suction lift is less than specified in section 2.1 Specifications and the fluid has a specific gravity of water and viscosity of less than 50 cPs (centipoise). For denser or more viscous solutions, consult distributor.

Note that suction conditions can affect the performance of the pump. This effect is more pronounced with lower pressure pumps. Consult your distributor for additional information.

Your LMI metering pump must be mounted so that the suction and discharge valves are vertical.

 **CAUTION** NEVER POSITION PUMP HEAD AND FITTINGS HORIZONTALLY.

3.2.1 Flooded Suction

For flooded suction, the pump is mounted at the base of the storage tank. This installation is the most trouble-free, and is recommended for very low outputs, solutions that gasify, and high-viscosity solutions. Since the suction tubing is filled with solution, priming is accomplished quickly and the chance of losing prime is reduced. A foot valve is not necessary in a flooded suction installation.

CAUTION WHEN PUMPING DOWNHILL OR INTO A LOW OR NO PRESSURE SYSTEM, A BACKPRESSURE / ANTI-SYPHON DEVICE SHOULD BE INSTALLED TO PREVENT OVER PUMPING OR SYPHONING.

Although popular for all solutions, LMI recommends flooded suction installations for all high-viscosity fluid applications.

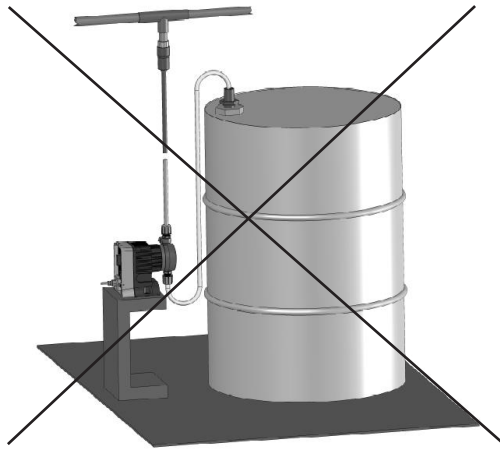

INCORRECT

Avoid this type of false flooded suction

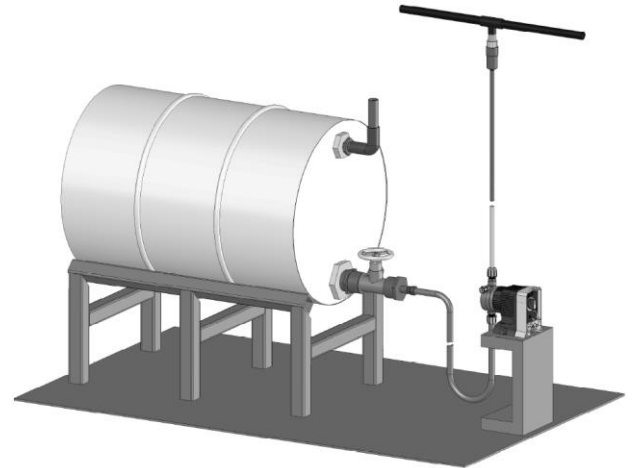

CORRECT

Figure 1: Flooded Suction Pump Mount

SECTION 3 - INSTALLATION

3.3 Tubing Connections

Use only LMI supplied tubing with your pump, as the tubing is specifically designed for use with the pump fittings. Before installation, all tubing must be cut with a clean square end. Valve and head connections from the factory are capped or plugged to retain pre-prime water. Remove and discard these caps or plugs before connecting tubing.

CAUTION DO NOT USE PLIERS OR PIPE WRENCH ON COUPLING NUTS OR FITTINGS.

CAUTION DO NOT REUSE FERRULES — USE ONLY NEW FERRULES.

1. Insert tubing through coupling nut. Tubing should enter the smaller end of the coupling nut first, orienting the larger opening of the coupling nut toward the tubing end.
2. Position a female ferrule about 1 in (25 mm) from end of tubing. For 3/8 in and 8 mm tubing, orient the raised collar of the female ferrule toward the coupling nut.
3. Insert the male ferrule onto the end of the tube, pushing the tube into the bottom of the groove or base.
4. Slide the female ferrule down the tubing and with your fingers, press tightly into the male ferrule (Figure 2).
5. Firmly hand tighten the Coupling Nut onto the fitting.

NOTE:

Tightening with pliers may cause the ferrules to break.

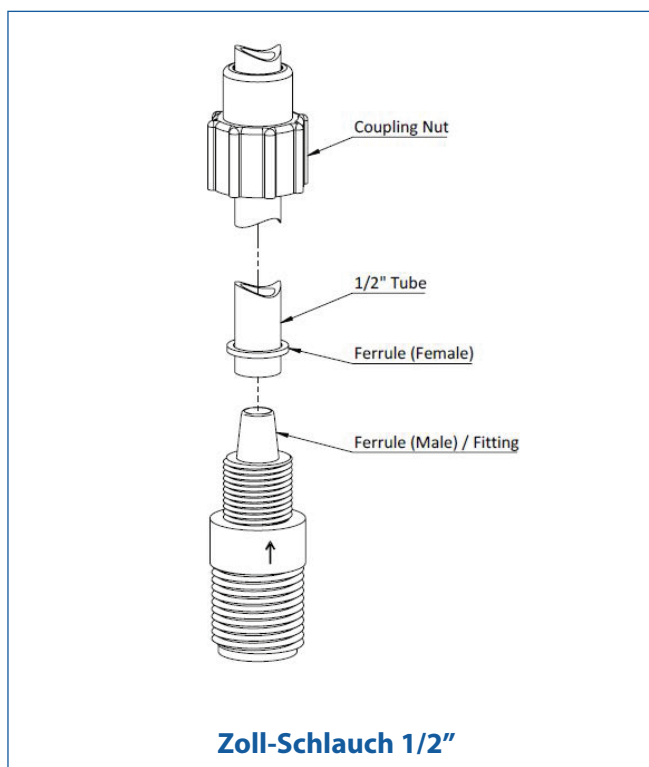

Replacement ferrules and coupling nuts are available as the following kit numbers:

54714 - 3/8" TUBE

54715 - 1/4" x 1/2" HOSE

54716 - 8 mm TUBE

54717 - 6 x 12mm HOSE

54718 - 1/2" TUBE

One kit is needed for each end of the tube.

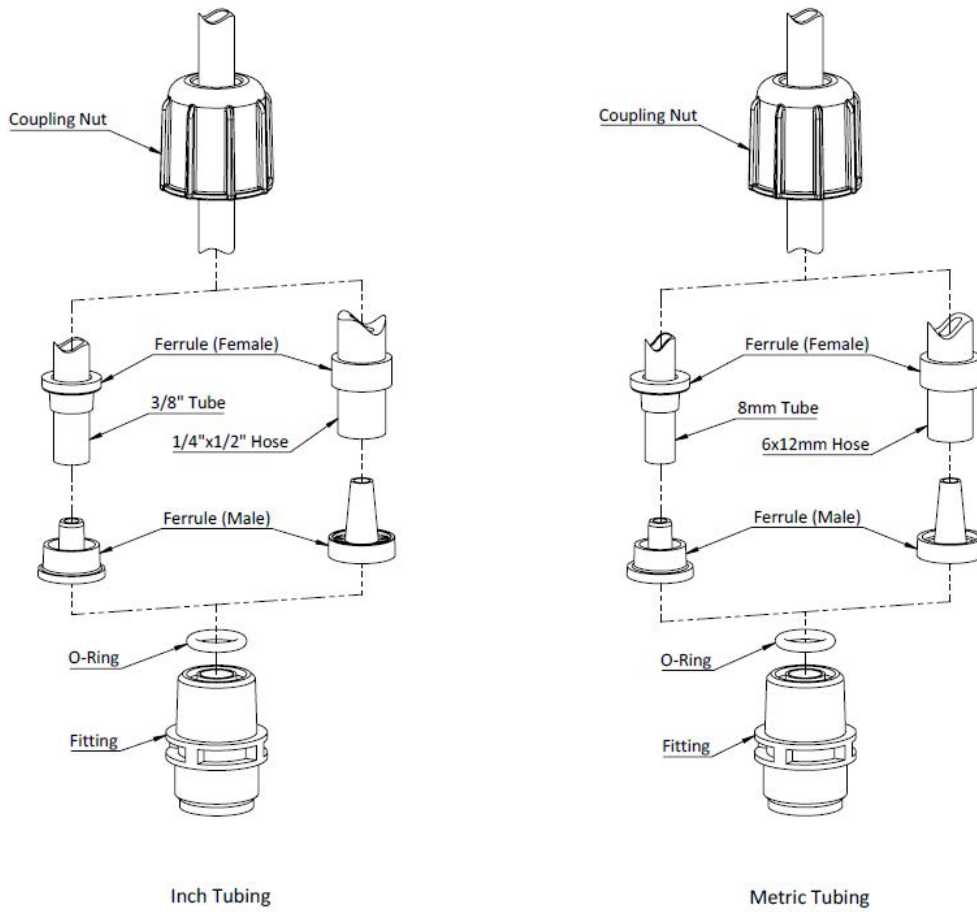

Figure 2: Ferrule Assembly

SECTION 3 - INSTALLATION

3.4 Foot Valve / Suction Tubing Installation

The foot valve acts as a check valve to keep the pump primed in suction lift applications.

The foot valve is designed to be submersed in the solution tank or drum and must sit in a vertical position at the bottom. Position approximately 2 in (50 mm) above the bottom of the tank or drum sediment layer.

The ceramic weight, when installed, helps position the foot valve in a vertical position.

1. Attach the foot valve to one end of the suction tubing (see section 3.3 Tubing Connections).
2. Slide the ceramic weight over the tubing end until it contacts the top of the foot valve coupling nut.

3. Place foot valve and tubing into the solution tank. Check that the foot valve is vertical and approximately 2 in (50 mm) from the bottom of the tank or drum (Figure 3). Connect the other end of the tubing to the suction side of the pump head (bottom side) (see section 3.3 Tubing Connections).

Note:

Pump models equipped with high-viscosity liquid ends are not equipped with foot valves. Flooded suction is recommended. A 1/2 in NPT connector is included for flooded suction installations.

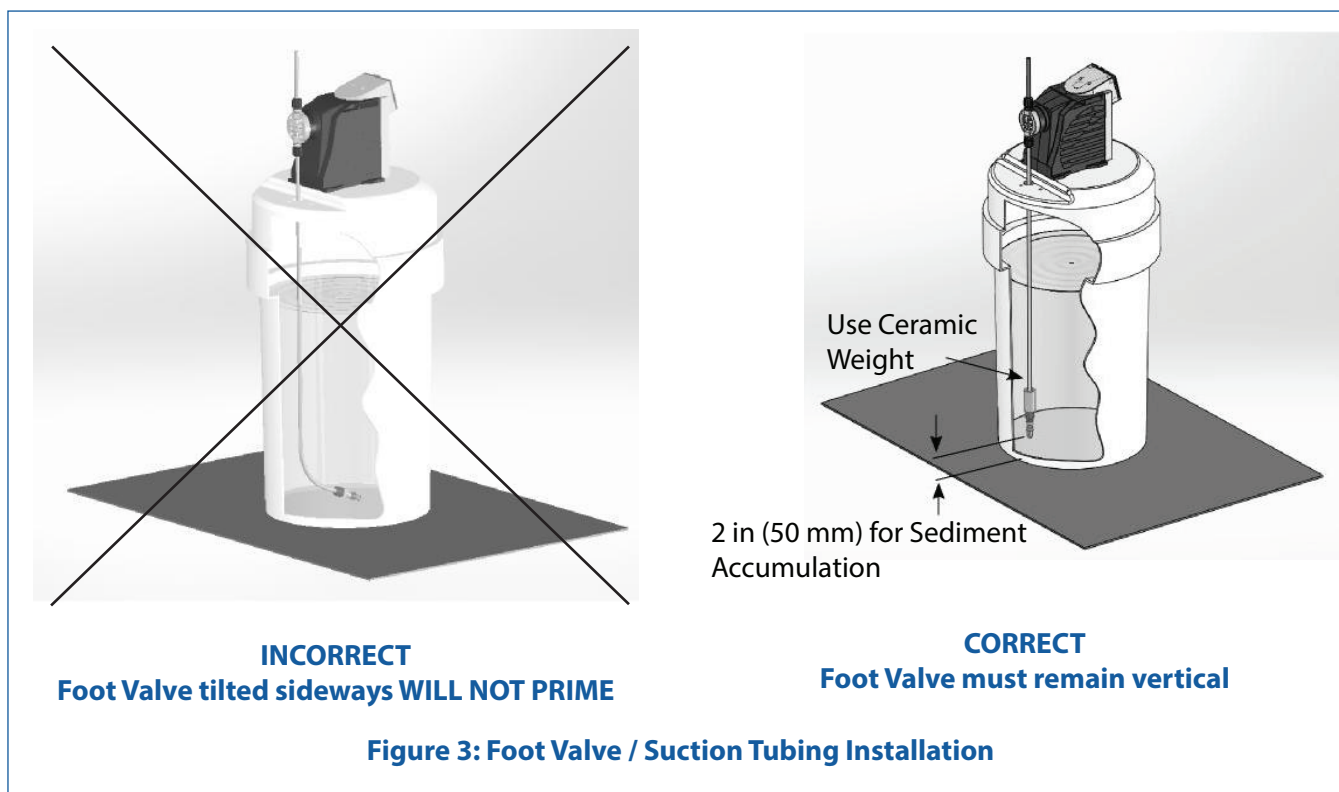

3.5 Injection Check Valve and Discharge Tubing Installation

The injection check valve prevents backflow from a treated line.

1. Install the injection check valve at the location where chemical is being injected into the system. Any size female NPT fitting or pipe tee with a reducing bushing to ½ in female NPT will accept the injection check valve. PTFE tape should only be used on threads that are connected with pipes.
2. When installing the injection check valve, be sure to position it so that the valve enters the bottom of your pipe in a vertical position. Variations left and right within 80° are acceptable (Figure 4).
3. After cutting an appropriate length of tubing, connect tubing to the injection check valve then back to the discharge side of the pump head. Make sure it does not crimp or come into contact with hot or sharp surfaces (see section 3.3 Tubing Connections).

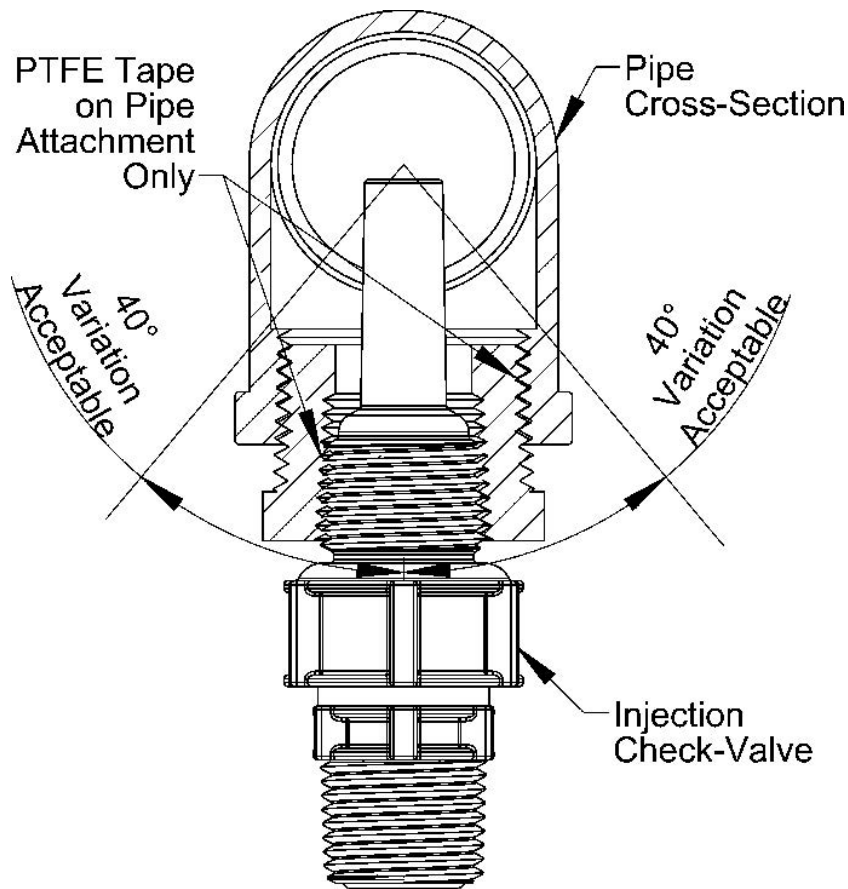
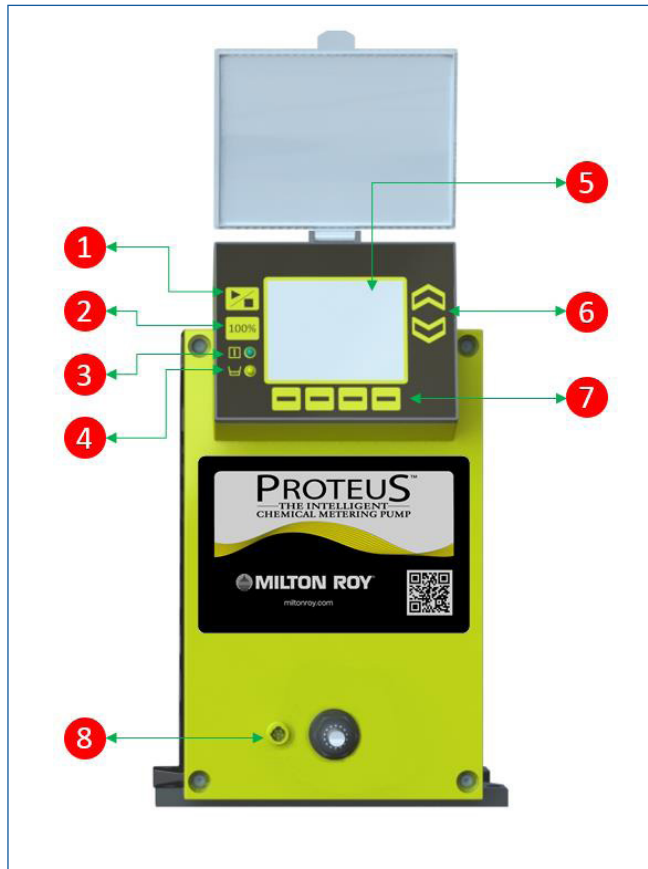

Figure 4: Typical Injection Check Valve Installation

SECTION 4 - OPERATION

This manual covers features supported in the manual control model Excel XR® Series pumps.

4.1 Controls, Inputs and Outputs



1. **Start / Stop Button:** Starts or stops the pump. It affects only the pumping function. The pump is always powered when it is plugged in.
2. **Full Capacity Button:** Sends the pump output to 100% regardless of current settings.
3. **Pump Status Indicator:** Glows green constantly when pump is operating, including between strokes.
4. **Low Level Indicator:** Glows amber when tank sensor detects a low fluid level.
5. **LCD Display:** Shows current pump status, operating mode, settings, alarms, etc.
6. **Up / Down Multi-Function Buttons:** Function varies with the active display screen. Used for incrementing, decrementing and navigation.
7. **Multi-Function Buttons:** Function varies with the active display screen and is indicated by on-screen icons above the buttons. Used to highlight, select and navigate.
8. **Input / Output Connector:** This connector is used for the special functions associated with the Manual controls (e.g., Digital Input).

4.2 Display Screen and Keypad

All control input and monitoring of pump status is done using the display screen and keypad. All inputs entered while the pump is running affect pump output immediately. If changes are made while the pump is at idle, the new settings will be in effect when the pump is started.

4.2.1 Pump Start / Stop

The **Start / Stop** button toggles the pump ON and OFF, independent of other settings. When running it will operate based on the settings and external signals currently in effect. There is no need to stop the pump to change settings. When the pump is on, the pump status indicator will glow green.

4.2.2 Full Capacity Operation

If the **100%** button is pressed, the current settings and external signals will be temporarily overridden. Pump output will go immediately to full capacity and remain there. If the pump is not running when the **100%**

button is pressed, it will start and run at full capacity. To exit full capacity operation, press the **Start / Stop** button to stop the pump. The previous settings will resume. Press the **Start / Stop** button again to start the pump.

4.2.3 Multi-Function Buttons

The icon above each **Multi-Function** button indicates the function the button will perform. This function varies based on the active display screen. These buttons can highlight, select, navigate or increment as needed for the current display screen function.

4.2.4 Notification Bar

The notification bar (Figure 5) provides information at a glance including status icons to indicate operating mode, alarms, etc. depending on the display screen function.

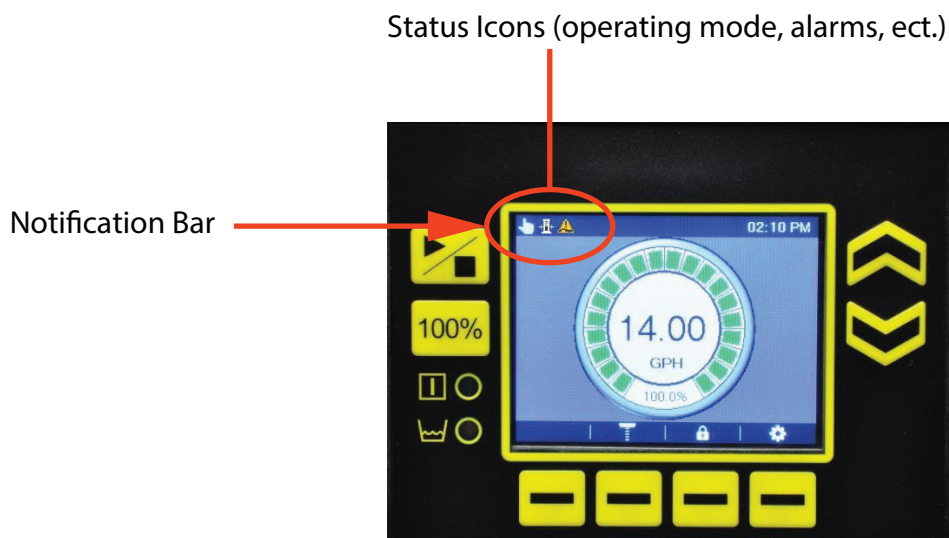

Figure 5: Notification Bar

SECTION 4 - OPERATION

4.2.5 Display Navigation

Navigation through display screens is done using the Up, Down, and Multi-Function buttons. The settings screen is shown in the example below (Figure 6). The scroll bar on the side of the display screen indicates there are more settings available on another page.

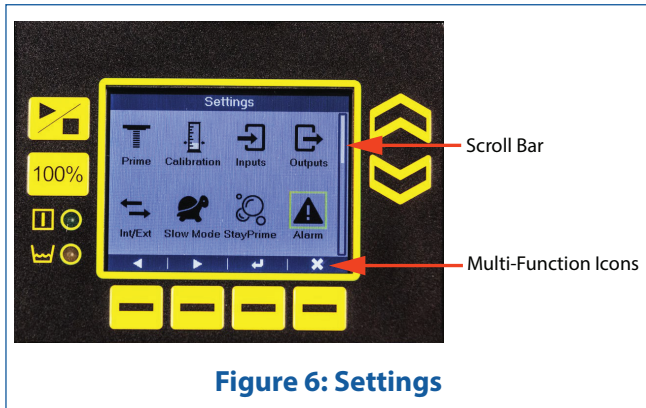

Figure 6: Settings

4.2.6 Icons

- Manual mode (other modes not available on Manual Control pumps)
- Left
- Right
- Save
- Enter
- Exit
- Settings
- Keypad locked (see section 4.4.5 Keypad Lock Functions)
- Reset
- Alarm Log (see section 4.4.5 Alarm Log)
- Pump has been calibrated (see section 4.6 Calibration)
- StayPrime active (see section 4.4.13 StayPrime)
- Slow mode active (see section 4.4.14 Slow Mode)
- Pump running at full capacity

- Prime mode (see section 4.5 Start-Up / Priming)
- Motor stalling
- Tank low level alarm (see section 4.4.15 Configure Input)
- Tank empty alarm (see section 4.4.15 Configure Input)
- Pump totals (see section 4.4.11 Totalizer)
- User totals (see section 4.4.11 Totalizer)
- Check (see section 4.4.8 Reload Factory Defaults)
- Problem homing the motor
- System error (Boot up error)

Table 3 shows the function of display screen icons.

Table 3: Pump Icons

4.3 Manual Mode

In Manual mode, the pump responds to the flow rate entered by the user. A configurable external input, described in section 4.4.15 Configure Input, provides additional control.

With the home screen displayed (Figure 7) press the **Up** or **Down** buttons to increase or decrease the desired flow rate. Changes can be made while the pump is running. The flow rate value will appear in the center of the gauge display and the green segments around the perimeter will light in 5% increments. The flow rate will also be shown in percent of full capacity below the flow rate.

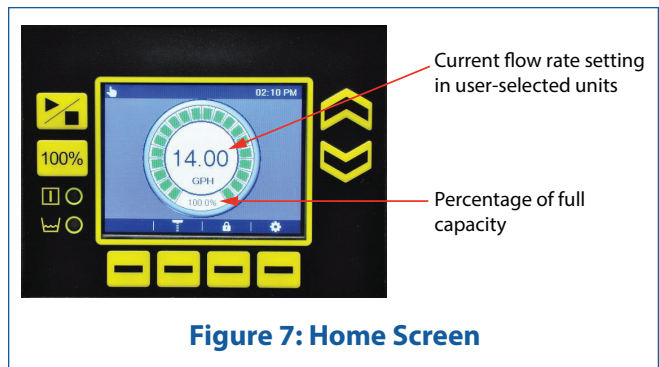



Figure 7: Home Screen

4.4 Settings

To access the settings screen (Figure 8) press **Settings**  in the home screen (Figure 7). Navigate to the function desired and press **Enter** .



Follow the prompts to enter new settings. New settings will need to be saved by pressing **Save** . Press **Exit**  to return to the previous screen without saving.



Figure 8: Settings

4.4.1 Prime Settings

See section 4.5 Start-Up / Priming, for use of this screen

4.4.2 Firmware Information

From the Settings screen, navigate to the **Firmware Rev.** icon and press **Enter** . The Firmware Rev. screen (Figure 9) will display firmware revision for several devices. This information is useful in troubleshooting or when contacting Customer Service.





Figure 9: Firmware Rev.

4.4.3 Calibration

See section 4.6 Calibration, for use of this screen.

4.4.4 Time / Day

Navigate between fields by pressing **Left**  or **Right** . On the Time/Day screen (Figure 10), set the time and day values by incrementing with the Up or Down buttons. Press **Save**  before exiting.

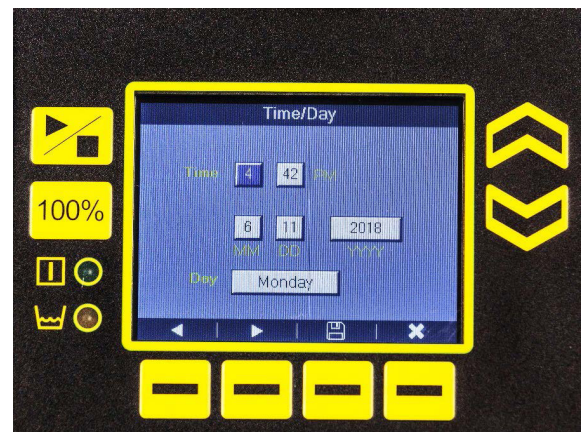





Figure 10: Time/Day

4.4.5 Alarm Log

Excel XR® can show a log of previous alarms and notifications. To access the **Alarm Log**, press the **Settings**  button from the home screen. Use the navigation buttons to select the **Alarm Logs** . The alarm log screen will show a list of alarms along with the time and date.

To clear the log, press Refresh . A menu will appear and ask if you want to clear the menu. Press **Yes** to clear or **No** to cancel.

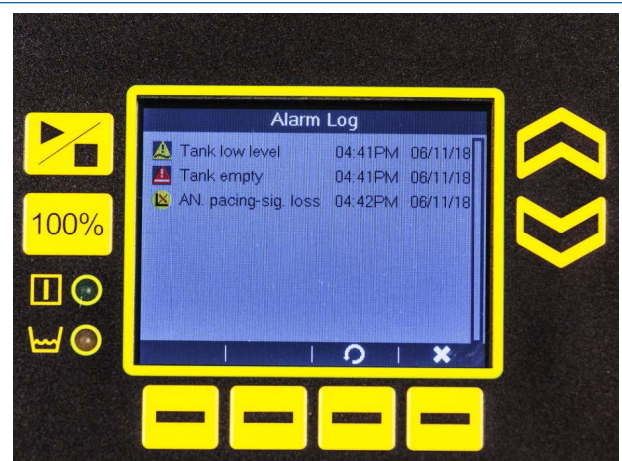









Figure 11: Alarm Log

SECTION 4 - OPERATION

4.4.6 Keypad Lock Functions

The keypad can be locked to prevent unintentional changes, or to limit access to only those with a password (Figure 12).

KEYPAD LOCK MODES

	Always unlocked (default)
	All buttons locked except Start / Stop button; Can be unlocked by pressing Lock 
	All buttons locked; Can be unlocked by pressing Lock 
	All buttons locked except Start / Stop button; Requires password to unlock
	All buttons locked; Requires password to unlock

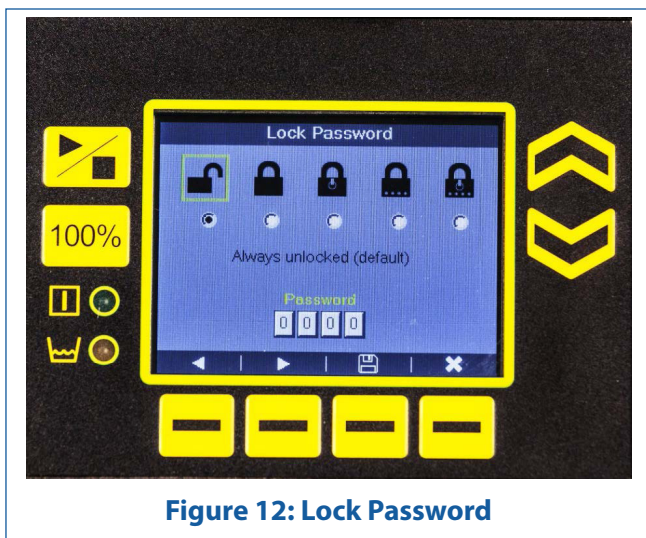











Figure 12: Lock Password

1. Set the lock function and select a password by selecting the type of protection desired by highlighting the desired icon.
2. Navigate to the number field.
3. Navigate from number to number by pressing **Left**  or **Right** .
4. Select the desired password numbers with the **Up** or **Down** buttons.
5. Press **Save**  before exiting.

If the keypad lock is enabled and set to a mode that does not require a password, simply press **Lock**  to engage or disengage the keypad lock. The **Lock**  on will appear in the Notification Bar when the keypad is locked.

If the keypad lock is enabled in a mode that requires a password, pressing **Lock**  will display the password entry block (Figure 13).

1. Navigate from number to number by pressing **Left**  or **Right** .
2. Select the number in each position with the **Up** or **Down** button.
3. Press **Enter**  to submit the completed password or **Exit**  to return to the previous screen.

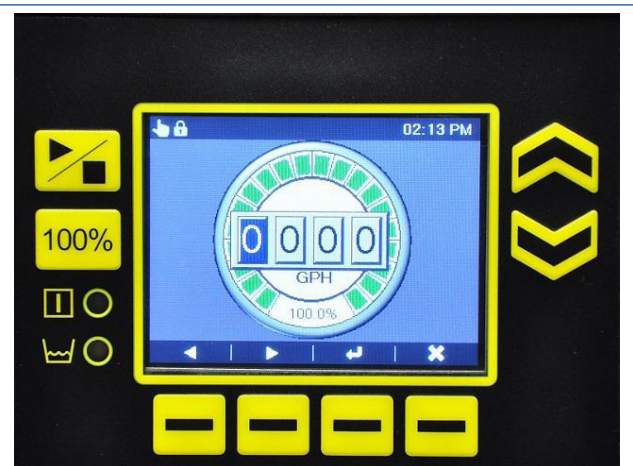





Figure 13: Password Entry Block

If the password entry block remains idle for several seconds it will time out and restore the home screen.

4.4.7 Set Liquid Measure Units

This system features U.S. and metric units. Select the preferred units by pressing **Left**  or **Right**  (Figure 14) and press **Save**  to retain the setting.

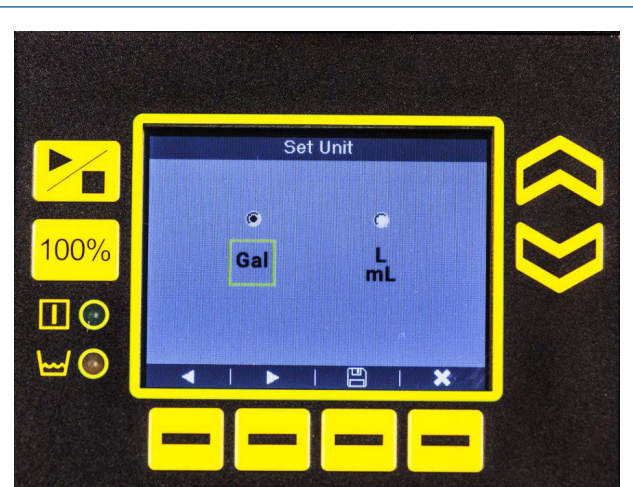

Figure 14: Set Unit

4.4.8 LCD Brightness



Display brightness is increased or decreased by pressing the **Up** or **Down** buttons (Figure 15). Press **Save**  before exiting to retain the new setting.



Figure 15: LCD Brightness

4.4.9 Reload Factory Defaults

All factory default settings can be restored by pressing the **Check**  (Figure 16).

A confirmation screen will appear as a precaution (Figure 17). Use the **Up** and **Down** buttons to select, press **Check**  to proceed. This action is not reversible.

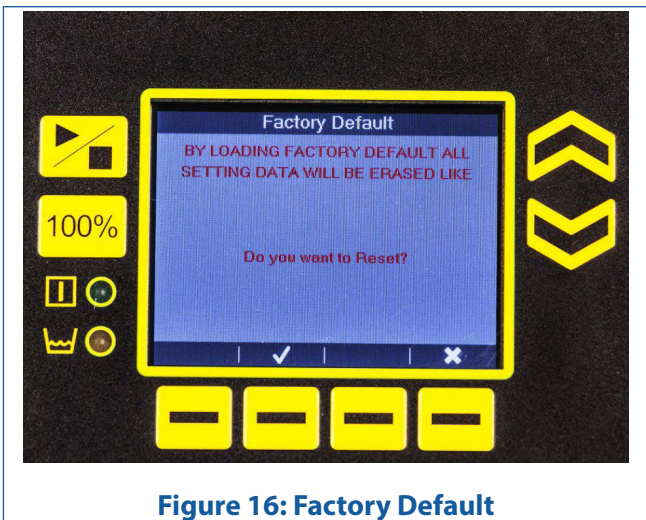

Figure 16: Factory Default





Figure 17: Factory Default Reset Verification

4.4.10 Power Loss Options

The manner of recovery from a power failure can be selected (Figure 18). The choices are:

- ◆ Stay Idle: Pump does not start (resume flow)
- ◆ Resume operation: Pump starts at the flow rate setting prior to power loss
- ◆ Run in speed: Pump starts at the flow rate specified

Navigate between options by pressing **Left**  or **Right** . If Run in Speed is selected, enter the desired speed using the Up or Down buttons. Press **Save**  to store the settings.

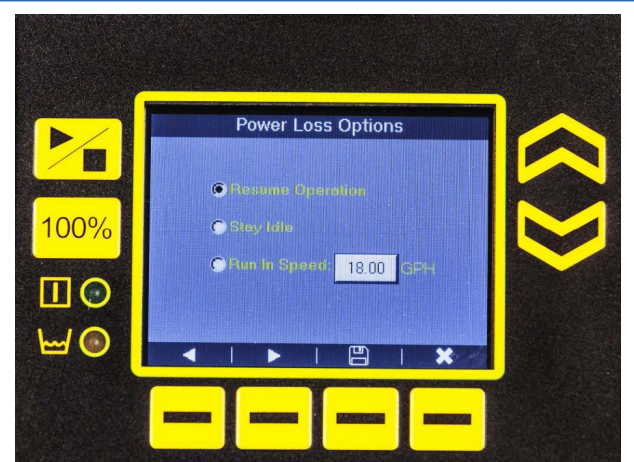

Figure 18: Power Loss Options

SECTION 4 - OPERATION

4.4.11 Totalizer





The totalizer function shows cumulative information in two modes: pump totals and Totals since last user reset. Pump totals cannot be altered and are not reset by loading factory defaults. View the pump totals by pressing **Pump** . View the user totals by pressing **User**  (Figure 19). Pressing **Reset**  changes all the user total values to zero.



Figure 19: Totalizer

4.4.12 Change Language

Select the desired language using the Up or Down buttons (Figure 20). Press **Save**  before exiting.

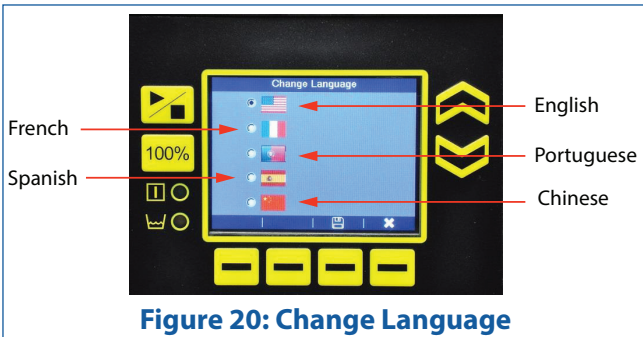



Figure 20: Change Language

4.4.13 StayPrime™ Degassing Technology

Excel XR® is equipped with **StayPrime™** Degassing Technology that assists in maintaining prime by running the pump at 100% for a short duration when power is applied and after a specified idle time thereafter. Note that if the power is removed after the pump is stopped, **StayPrime™** will not run. StayPrime™ is most useful in the following applications:

- Pump with manual mode that is stopped at the end of a shift – **StayPrime™** will run the pump periodically overnight to maintain prime.
- Pump that is externally controlled (Remote Start/Stop or External Pulse) – **StayPrime™** will run the pump periodically to maintain prime.

Once enabled, this feature will run the pump as long as the pump is powered on, even if the pump is in **Manual Mode** with the capacity set to 0% or in **External Pulse Mode** with no incoming pulses. **Ensure tubing is connected while this feature is enabled.**

To enable, press the **Settings**  button from the home screen while the pump is stopped. Using the navigation buttons, select **StayPrime** . Once in the StayPrime™ screen, use the **Up** or **Down** buttons to select **Enabled** in the **Status** box.

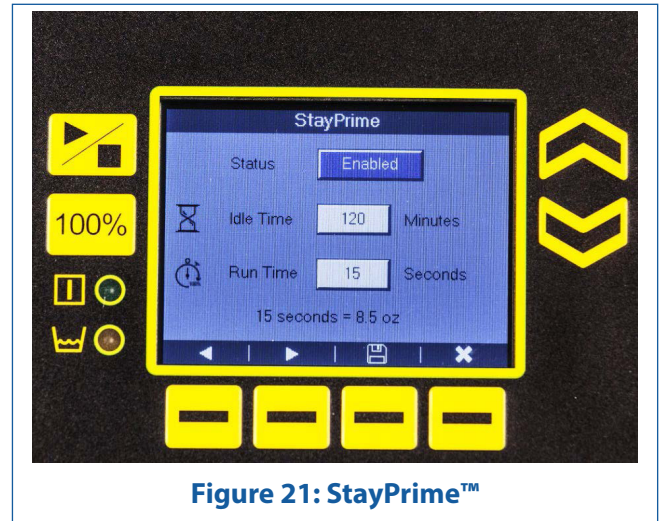







Figure 21: StayPrime™

To set the desired pump idle interval time, select **Idle Time** below using the **Right**  to select the box and the Up or Down buttons to enter the desired idle time.

To set the desired run time, select **Run Time** using the **Right**  to select the box and use the Up or Down buttons to enter the desired Run Time. To save the selected settings and enable, press **Save** .

StayPrime™ will remain active as long as  remains in the notification bar. When the priming sequence is engaged, the icon will turn green  while the pump is priming.

To disable, return to the **StayPrime™** screen and select **Disabled**, then press **Save** . The **StayPrime™** icon will no longer be appear on the notification bar.

4.4.14 Slow Mode

Slow mode is useful when pumping viscous fluids or those with a tendency to outgas (Figure 22). Slow mode reduces the speed of the pump motor on the suction stroke to minimize cavitation.

Press the **Up** or **Down** buttons to select the “**Slow Mode Active**” box. Press **Right** select the “%” box and the Up or Down buttons to enter the percentage of full capacity at which the pump should operate. Press **Save** to retain settings.



Figure 22: Slow Mode Settings

4.4.15 Configure Input

Pumps configured for manual control (one connector on the control panel) can accept one external input (Figure 23). On a manual control pump, the external input can be assigned to one of the following functions:

Input Type	Function	Use
Digital	<Disable>	De-activates input
	Remote Start/Stop	Externally toggles start/stop
	Tank Level Switch - Empty	Triggers “Tank Empty” alarm
	Tank Level Switch - Low	Triggers “Tank Low” alarm



Figure 23: Configure Input

1. Select the type of input by pressing **Left** or **Right**.
2. Select whether the input is “NC” (normally closed) or “NO” (normally open) with the **UP** and **Down** buttons
3. Press **Save** to retain the input assignment.

Operations / Indications

If configured for Remote **Start / Stop**, the control panel Start / Stop button overrides the Remote Start / Stop input. If the pump is stopped with the control panel button and the remote input is in the ON state, the pump will stop. To restart the pump remotely, the remote input must be cycled to the OFF state and back to ON again.

If the input is assigned to either of the Low Level functions, the ON state will illuminate the amber low-level indicator on the keypad. An icon will appear on the notification bar of the display to indicate that the tank is either low or empty (see section 4.2.6 Icons). If the input assignment is for Empty, the ON state will also stop the pump.

If the effect of the input is the opposite from what is desired (e.g., Low Level indication when the tank is full), return to the Configure Input screen and select the opposite of the original “NC” or “NO” entry. Press **Save**.

Connections

Input circuitry must be capable of switching 24 VDC at 15 mA (Figure 24). Minimum time in low impedance state (closed) is 25 ms. Minimum time in high impedance state (open) is 50 ms. The input is activated by making or breaking a connection between pin 4 (input) and pin 6 (ground) (Figure 25).

SECTION 4 - OPERATION

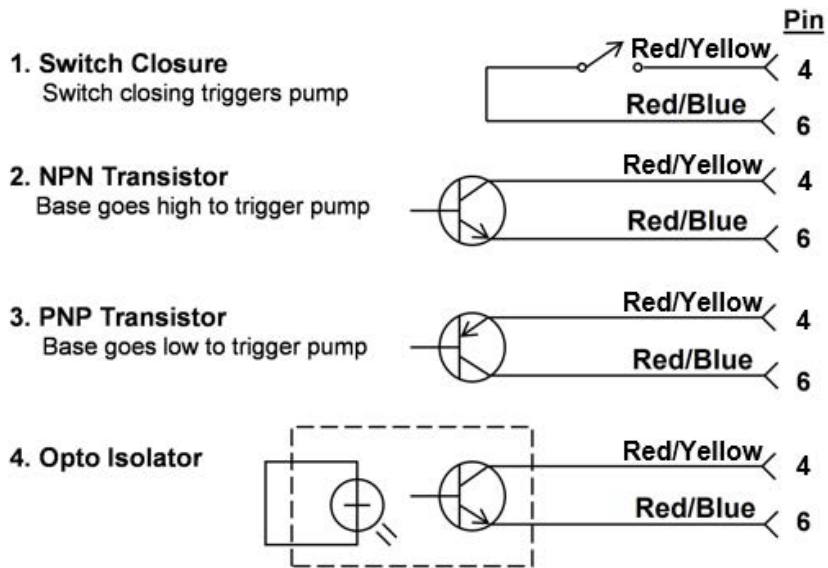
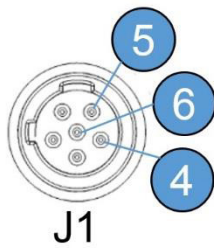

Figure 24: Input Diagram (J1)



Pin #	Function
4	Input
5	+24 VDC
6	Ground



Figure 25: Pin Diagram

4.5 Start-Up / Priming

Read this entire section completely before proceeding.

Pumps are shipped from the factory with water in the pump head to aid in priming. If your solution is not compatible with water, refer to the "Water Pre-Prime" paragraph in section 1.0 Precautions. The pump is normally self-priming. The priming procedure varies with the application. Time and flow rate for priming can be adjusted to suit the user's needs.

If suction lift is less than that specified in section 2.1 Specifications, proceed with the following steps.

1. From the Settings screen, select **Prime Settings** (Figure 26).
2. Press **Left**  or **Right**  to move between the Duration and Speed settings.
3. Enter the desired settings using the **Up** or **Down** buttons.
4. Press **Save**  to retain the settings. Allowable settings are as follows:

Settings	Minimum	Maximum
Duration (seconds)	1	3600
Flow Rate (user selected units)	0.01	Maximum Pump Capacity

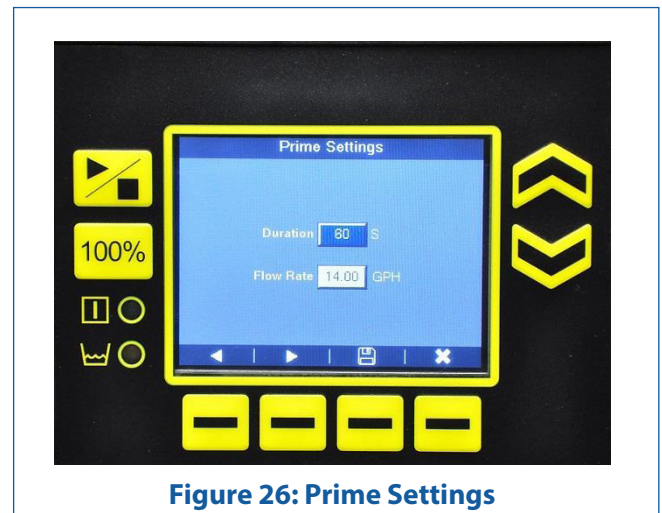



Figure 26: Prime Settings

The pump may be primed only after all settings have been entered, all precautionary steps have been taken (see section 1.0 Precautions), and after verification that all tubing is properly attached.

1. Plug in the pump and allow it to initialize.
2. Remove pressure from the discharge line with a priming valve or other method.
3. On the home screen, press **Prime** .
4. The pump will start at the rate selected. If slow mode is active, it will apply to priming as well. The suction tubing should begin to fill with solution.
5. Once the pump is primed, it may be turned off manually or it will shut off automatically after the duration previously set.
6. Close the priming valve and stop the pump.
 - a. If the pump has trouble achieving an initial prime, remove the fitting and check valve on the discharge side of the pump head.
 - b. Pour some of the pumped solution into the port until the head is filled.
 - c. Replace the valve and fitting, then follow the priming steps again.

SECTION 4 - OPERATION

4.6 Calibration

The pump is equipped to display a theoretical flow rate based upon the pump's stroke speed. These calculations are based on factory test conditions, which may be significantly different from your application. The true flow rate for a given pump output setting can vary depending on many factors including: pressure, temperature, fluid medium, and system layout. It is recommended that the pump be calibrated before use under application conditions. This one-point calibration procedure will greatly improve the accuracy of the pump's theoretical flow rate display.

1. Prepare a device for accurately measuring volume such as a graduated cylinder or a scale sensitive to 1 gram. If using a graduated cylinder, make sure the fluid surface area remains constant during calibration, e.g., the fluid remains above the foot valve weight as shown in Figure 29.
2. Ensure the pump is primed following the procedure in 4.5 Start-Up / Priming. Verify that the discharge line is at normal operating pressure.
3. On the Settings screen, select **Calibration**. The Flow Rate box is pre-selected (Figure 27).
4. Use the **Up** or **Down** button to set a flow rate typical of normal operating conditions.



Figure 27: Pump Calibration (Set Flow Rate)

5. Take a beginning reading on the measuring device, e.g., starting fluid height, tare weight, set scale to zero, etc.
6. Press the **Start / Stop** button and the pump will start and begin counting strokes (Figure 28). Allow the pump to run as long as possible. Calibration accuracy improves with more strokes. (The maximum number of strokes is 9999.) If using a graduated cylinder with a foot valve, keep the fluid level above the valve and weight.

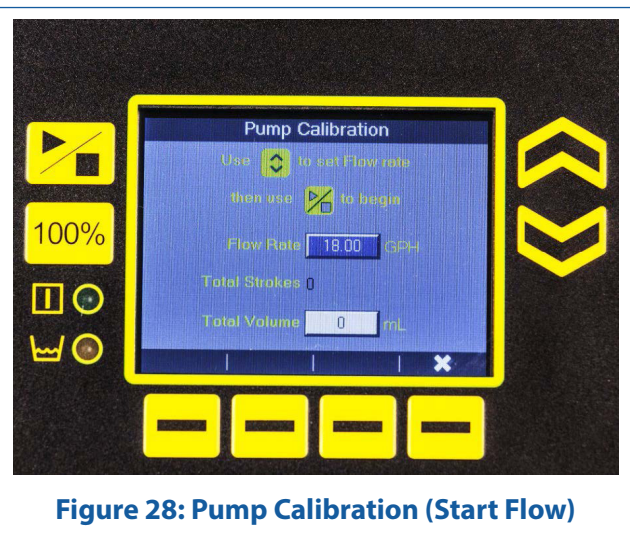

Figure 28: Pump Calibration (Start Flow)

7. Press the **Start / Stop** button to stop the pump. The screen will display the number of strokes and the estimated Total Volume pumped. The units of total volume are always in ml to allow a direct reading from the cylinder.
8. Take the final reading of fluid volume in ml. If using a scale, divide the difference between beginning and ending weights in grams by the specific gravity of the chemical solution being pumped. If using a graduated cylinder with a foot valve inserted (Figure 29), the readings will need to be adjusted to compensate for the presence of the suction tubing using the following formula:

SECTION 4 - OPERATION

$$V_{\text{actual}} = V_{\text{observed}} (1 - (D_{\text{tube}}/D_{\text{column}})^2)$$

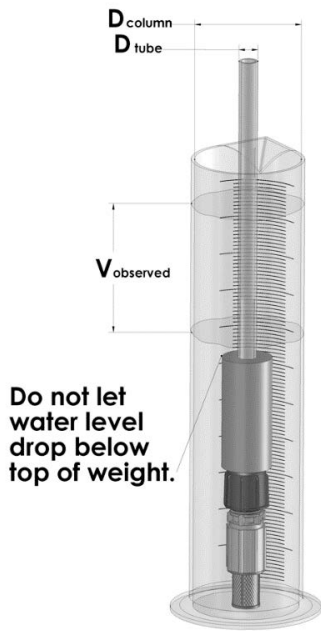

Figure 29: Graduated Cylinder

For accuracy, it is important that the water level does not drop below the top of the ceramic foot valve weight.

Note:

If you will be using the pump at a different pressure, the pump should be recalibrated under those conditions using the procedure above to ensure accuracy.

- The total volume box will be highlighted (Figure 30). Using the **Up** or **Down** buttons, enter the actual volume measured during the calibration.
- Press **Save** The **Calibrated** icon will display on the home screen.



Figure 30: Pump Calibration

If at any time during the calibration procedure the process needs to be re-run, press **Reset** . If necessary, the **Calibration** icon on the home screen can be cleared by restoring factory defaults.

Note:

If the pump is subsequently used at a significantly different pressure, it should be recalibrated under the new conditions following the above procedure to ensure accuracy.

SECTION 5 - MAINTENANCE

5.1 Spare Parts Replacement and Routine Maintenance

LMI metering pumps are designed for trouble-free operation, yet routine maintenance of elastomeric parts is essential for optimum performance. This involves replacing the diaphragm, cartridge valves, O-rings, and the injection check valve spring. LMI recommends replacing these parts at least once a year; however, frequency will depend on your particular application.

5.2 Depressurizing the Discharge Line

CAUTION ALWAYS WEAR PROTECTIVE CLOTHING, FACE SHIELD, SAFETY GLASSES AND GLOVES WHEN WORKING ON OR PERFORMING ANY MAINTENANCE OR REPLACEMENT ON YOUR PUMP. SEE SDS INFORMATION FROM SOLUTION SUPPLIER FOR ADDITIONAL PRECAUTIONS.

TO REDUCE THE RISK OF CHEMICAL SPLASH DURING DISASSEMBLY OR MAINTENANCE, ALL INSTALLATIONS SHOULD BE EQUIPPED WITH LINE DEPRESSURIZATION CAPABILITY.

READ THE FOLLOWING BEFORE PROCEEDING.

1. Be sure the injection check valve is properly installed and is operating. If a shut off valve has been installed downstream of the injection valve, it should be closed.
2. Be sure your relief tubing is connected to your priming/relief valve and runs back to your solution drum or tank.
3. Open the priming/relief valve until solution drains back down the discharge tubing into the solution tank or drum, and the discharge line is fully depressurized.

5.3 Diaphragm Replacement

ALWAYS wear protective clothing, face shield, safety glasses and gloves when working on or performing any maintenance or replacement on your pump. See SDS information from solution supplier for additional precautions.

Refer to the LMI Metering Pump Price List for the proper Spare Parts Kit number or contact your local LMI stocking distributor. Spare Part Replacement Kits include specific instructions for diaphragm replacement. Please follow the instructions included with the replacement kit. When replacing the diaphragm, the cartridge valves, or O-rings, the injection check valve spring should also be replaced (see section 5.4 Injection Check Valve Parts Replacement).

1. Carefully depressurize, drain, and disconnect the discharge line (see section 5.1 Depressurizing the Discharge Line).
2. Place the foot valve or suction tube into a container of water or other neutralizing solution.
3. Turn the pump on to flush the head assembly.
4. Once the pump head has been flushed, remove the foot valve or suction tube from the solution and continue to pump air into the pump head until the pump head is purged of water or neutralizing solution (Figure 31).

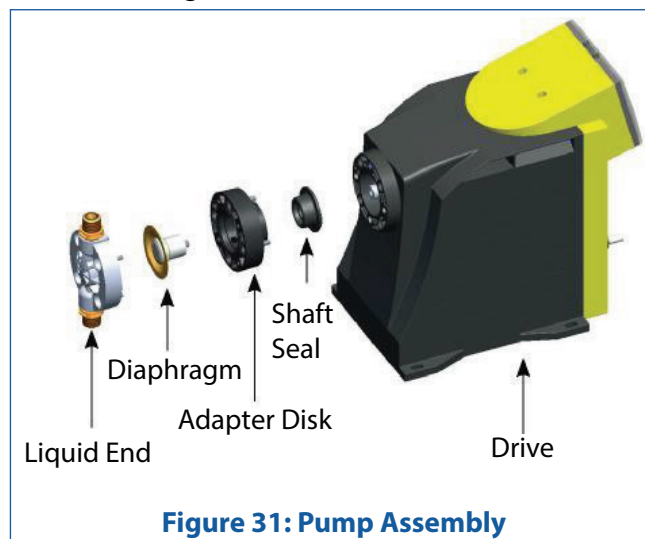



Figure 31: Pump Assembly

Note:

If the liquid cannot be pumped due to diaphragm rupture, carefully disconnect the suction and discharge tubing using protective clothing, gloves, and face shield. Immerse the head in water or other neutralizing solution.

5. Remove the screws and washers from the head.
6. On the Settings screen, select Diaphragm Replacement and press **Enter** .
7. Press **Left**  to fully extend the diaphragm to the full out position (Figure 32).

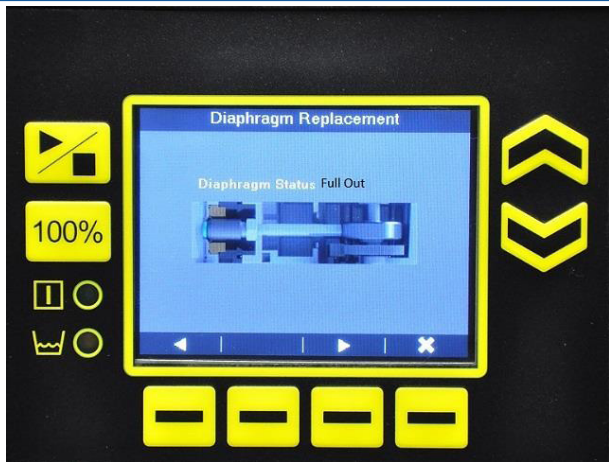



Figure 32: Diaphragm Replacement (Full Out)

8. Unscrew the diaphragm by carefully grasping the outer edge and turning it counter-clockwise. Discard old diaphragm.
9. Remove the adapter disk and check condition of the shaft seal. Replace shaft seal if necessary.
10. Replace the adapter disk so that the drain hole of the disk is oriented downward, and the mounting holes line up with the mounting holes of the pump.

CAUTION BE CAREFUL NOT TO SCRATCH THE FLUOROFILM™ FACE OF THE NEW DIAPHRAGM.

11. Screw on the new diaphragm clockwise until turned all the way in.
 12. Press **Right**  to fully retract the diaphragm to the full in position (Figure 33).
 13. Remount the pump head using the screws and washers.
 14. Tighten in a crisscross pattern.
 15. Torque screws to 25 inch-pounds.
- After one week of operation, recheck the screws and tighten if necessary.

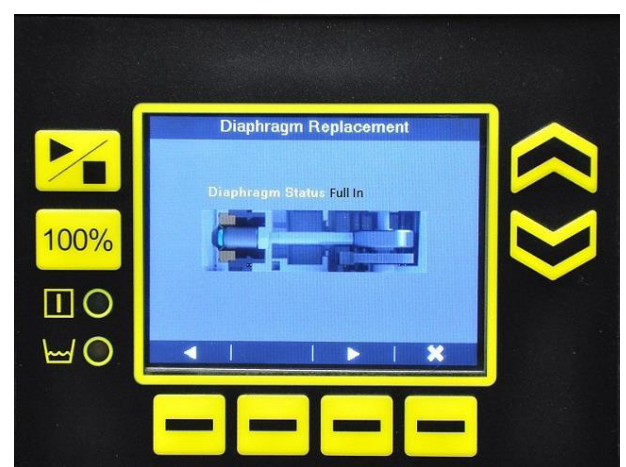

Figure 33: Diaphragm Replacement (Full In)

SECTION 5 - MAINTENANCE

5.4 Cartridge Valve and O-ring Replacement

ALWAYS wear protective clothing, face shield, safety glasses and gloves when working on or performing any maintenance or replacement on your pump. See SDS information from solution supplier for additional precautions.

Refer to the LMI Metering Pump Price List for the proper Spare Parts Kit number or contact your local LMI stocking distributor. Spare Part Replacement Kits include specific instructions for valve replacement. Please follow the instructions included with the replacement kit.

1. Carefully depressurize and disconnect the discharge line (see section 5.1 Depressurizing the Discharge Line).
2. Place the foot valve or suction tube into a container of water or other neutralizing solution.
3. Turn the pump on to flush the head assembly.
4. Once the pump has been flushed, lift the foot valve out and continue to pump to let air into the pump head until pump is purged of water or neutralizing solution.

Note:

If the liquid cannot be pumped due to diaphragm rupture, carefully disconnect the suction and discharge tubing using protective clothing, gloves, and face shield. Remove the screws and washers from the head and immerse the head in water or other neutralizing solution.

5. Carefully disconnect one tubing connection and fitting one at a time, then remove and replace the worn valve and O-rings. If necessary, carefully loosen stuck valves by prying side to side using a small screwdriver through the center hole of the valve. Before disassembling the check valves, note the orientation of the valve.
6. Install new check valves in each location. Ensure that the cartridges are oriented correctly.

ALWAYS wear protective clothing, face shield, safety glasses and gloves when working on or performing any maintenance or replacement on your pump. See SDS information from solution supplier for additional precautions.

Refer to the LMI Metering Pump Price List for the proper Spare Parts Kit number or contact your local LMI representative. Spare Part Replacement Kits include specific instructions for valve replacement. Please follow the instructions included with the replacement kit.

Depressurize and drain pipeline (or isolate injection check valve point using valves) so that injection check valve can safely be disassembled.

1. Isolate injection check valve and depressurize pipe or drain pipeline.
2. Carefully depressurize and disconnect the discharge line (see section 5.1 Depressurizing the Discharge Line).
3. Carefully disconnect the tubing leading to the injection check valve (Figure 34).
4. Remove the injection check valve fitting.
5. Remove and replace the worn spring, seat, ball, and O-ring.

Note:

Before disassembling the check valve, note the orientation of the parts.

6. Install a new spring, seat, ball, and O-ring. Ensure that the parts are oriented correctly.

5.5 Injection Check Valve Parts Replacement

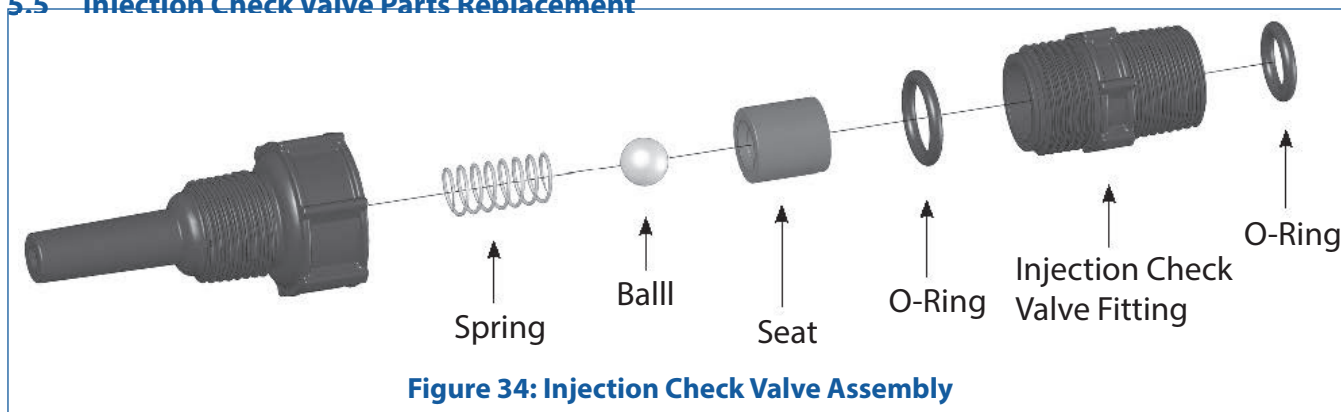

SECTION 6 - TROUBLESHOOTING

PROBLEM	POSSIBLE CAUSE	SOLUTION
Pump Will Not Prime	1. Pump not turned on or plugged in	1. Turn on pump/plug in pump
	2. Foot Valve not in vertical position on bottom of tank	2. Foot valve must be vertical (see section 3.4 Foot Valve / Suction Tubing Installation)
	3. Pump suction lift too high	3. Maximum suction lift, specified in section 2.1 Specifications. High viscosity liquid handling assemblies require flooded suction
	4. Suction tubing is curved or coiled in tank	4. Suction tubing must be vertical. Use LMI ceramic weight supplied with pump (see section 3.4 Foot Valve / Suction Tubing Installation)
	5. Fittings are overtightened	5. DO NOT OVERTIGHTEN FITTINGS! This causes seal rings to distort and not seat properly which causes pump to leak back or lose prime
	6. Air trap in suction valve tubing	6. Suction tubing should be as vertical as possible. AVOID FALSE FLOODED SUCTION! (see section 3.2.1 Flooded Suction)
	7. Too much pressure at discharge	7. Shut off valves in pressurized line. Disconnect tubing at injection check valve (see section 4.4.1 Prime Settings). When pump is primed, reconnect discharge tubing
	8. Air leak around fitting	8. Check for missing or damaged O-rings at ends of fittings
Pump Loses Prime	1. Solution container ran dry	1. Refill container with solution and re-prime (see Section 4.4.1 Prime Settings)
	2. Foot Valve is not in a vertical position on the bottom of the tank	2. Foot Valve must be vertical (see section 3.4 Foot Valve / Suction Tubing Installation)
	3. Pump suction lift is too high	3. Maximum suction lift, specified in section 2.1 Specifications. High viscosity liquid handling assemblies require flooded suction
	4. Suction tubing is curved or coiled in tank	4. Suction tubing must be vertical. Use LMI ceramic weight supplied with pump (see section 3.4 Foot Valve / Suction Tubing Installation)
	5. Fittings are over tightened	5. DO NOT OVERTIGHTEN FITTINGS! This causes seal rings to distort and not seat properly which caused pump to leak back or lose prime
	6. Air trap in suction valve tubing	6. Suction tubing should be as vertical as possible. AVOID FALSE FLOODED SUCTION! (see Section 3.2.1 Flooded Suction)
	7. Air leak on suction side	7. Check for pinholes, cracks. Replace if necessary

SECTION 6 - TROUBLESHOOTING

PROBLEM	POSSIBLE CAUSE	SOLUTION
Leakage at Tubing	1. Worn tubing ends	1. Cut about 1 in (25 mm) off tubing and then replace as before
	2. Loose or cracked fitting	2. Replace fitting if cracked. Carefully hand tighten fittings. DO NOT USE PIPE WRENCH. An additional 1/8 or 1/4 turn may be necessary
	3. Worn seal rings	3. Replace balls and seal rings (see section 5.3 Cartridge Valve and O-Ring Replacement)
	4. Solution attacking Liquid Handling Assembly	4. Consult your local distributor for alternate materials
Low Output or Failure to Pump Against Pressure	1. Pump's maximum pressure rating is exceeded by injection pressure	1. Injection pressure cannot exceed pump's maximum pressure. See pump data plate
	2. Worn Seal Rings	2. Worn seal rings or cartridge valves may need replacement (see section 5.3 Cartridge Valve and O-ring Replacement)
	3. Ruptured Diaphragm	3. Replace diaphragm (see section 5.2 Diaphragm Replacement)
	4. Tubing run on discharge may be too long	4. Longer tubing runs may create frictional losses sufficient to reduce pump's pressure rating. Consult factory for more information
	5. Clogged Foot Valve strainer	5. Remove Foot Valve strainer when pumping slurries or when solution particles cause strainer to clog
Failure to Run	1. Pump not turned on or plugged in	1. Turn on or plug in pump
	2. Electronic or Mechanical failure	2. Consult supplier or factory
Excessive Pump Output	1. Syphoning (Pumping downhill without an anti-siphon valve)	1. Move injection point to a pressurized location or install an anti-siphon valve
	2. Little or no pressure at injection point	2. If pressure at injection point is less than 30 psi (2.0 Bar), a backpressure valve should be installed

Milton Roy® is a brand of Ingersoll Rand. For more information, visit [ingersollrand.com](https://www.ingersollrand.com)



To learn more about the MILROYAL® Series metering pumps, contact your local representative or visit [miltonroy.com](https://www.miltonroy.com).

All information contained herein subject to change without notice.



About Ingersoll Rand

Ingersoll Rand Inc. (NYSE:IR), driven by an entrepreneurial spirit and ownership mindset, is dedicated to helping make life better for our employees, customers and communities. Customers lean on us for our technology-driven excellence in mission-critical flow creation and industrial solutions across 40+ respected brands where our products and services excel in the most complex and harsh conditions. Our employees develop customers for life through their daily commitment to expertise, productivity and efficiency. For more information, visit www.IRCO.com.

We are committed to using environmentally conscious print practices

©2023 Ingersoll Rand

54630