

Instruction Manual

Series E7

Metering Pumps

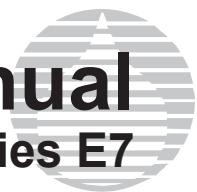

For file reference, please record the following data:

Model No: _____

Serial No: _____

Installation Date: _____

Installation Location: _____

When ordering replacement parts for your LMI Pump, please include the complete Model Number and Serial Number of your unit.



201 Ivyland Road
Ivyland, PA 18974 USA
TEL: (215) 293-0401
FAX: (215) 293-0445
<http://www.lmipumps.com>

Contents

1.0	Installation	3
1.1	Unpacking	3
1.2	Location and Mounting.....	3
	- Suction Lift Installation.....	3
	- Flooded Suction Installation.....	3
	- Prevent Syphoning	4
1.3	Electrical	4
	- Wiring for Accessories.....	5
	- Output Adjustment - Initial Approximation.....	5
	- Procedure for On-Site Volumetric Calibration E7 in Internal Mode.....	6
	- Procedure for On-Site Volumetric Calibration E7 in External Mode	6
2.0	Troubleshooting Liquid End	7
2.1	Low Pump Output	7
2.2	Excessive Pump Output.....	8
2.3	Changing Pumping Liquifram™ (Diaphragm)	8
3.0	Exploded View	10
4.0	Parts List	11

1.0 INSTALLATION

1.1 UNPACKING

Remove tubing, injection check and foot valve (if included) from the pump carton. Notify delivery carrier immediately if there are any signs of damage to the metering pump or parts.

1.2 LOCATION AND MOUNTING



a) When pumping solutions, make certain that all tubing is securely attached to the fittings. It is recommended that tubing or pipe lines be shielded to prevent possible injury in case of rupture or accidental damage. Always wear protective face shield and clothing when working on or near a chemical metering pump.

b) LMI accessories used with the Series E pumps must be placed in an explosion proof enclosure or located in an area where they will not be subjected to explosion hazard.

c) Be sure installation does not constitute a cross connection. Check local plumbing code.

- A. Locate the pump in an area that is convenient to both solution injection point and electrical supply. LMI Series E7 metering pumps have corrosion resistant housings, but should not be subjected to continuous high temperature (over 122° F or 50° C).
- B. Mount pump as shown below. Secure pump to shelf with 5/16" bolts through the four (4) holes in the pump base. Shelf must be able to support 50 lbs minimum (23 kg).
- C. Figures 1 and 2 (below) show typical metering pump installation methods. Note location of injection check valve which is most important. Refer to separate Liquid Handling Assembly Instructions Section A regarding installation of injection check valve.

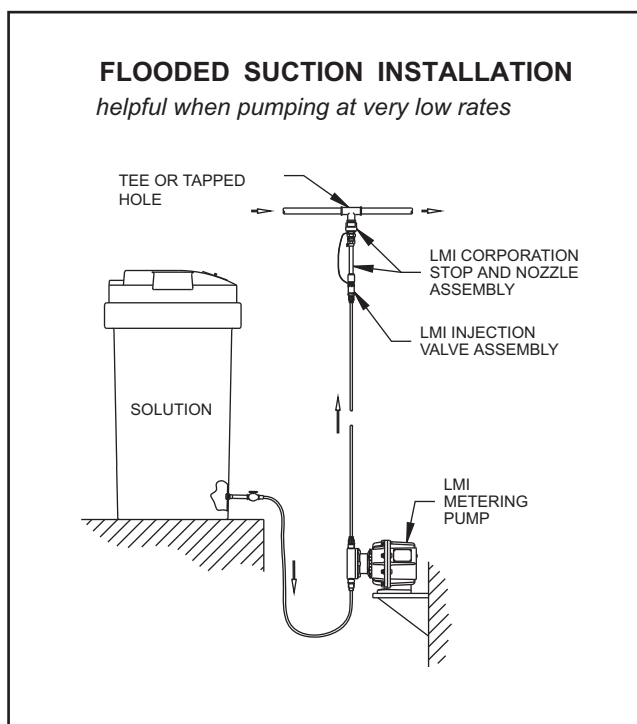

Figure 1

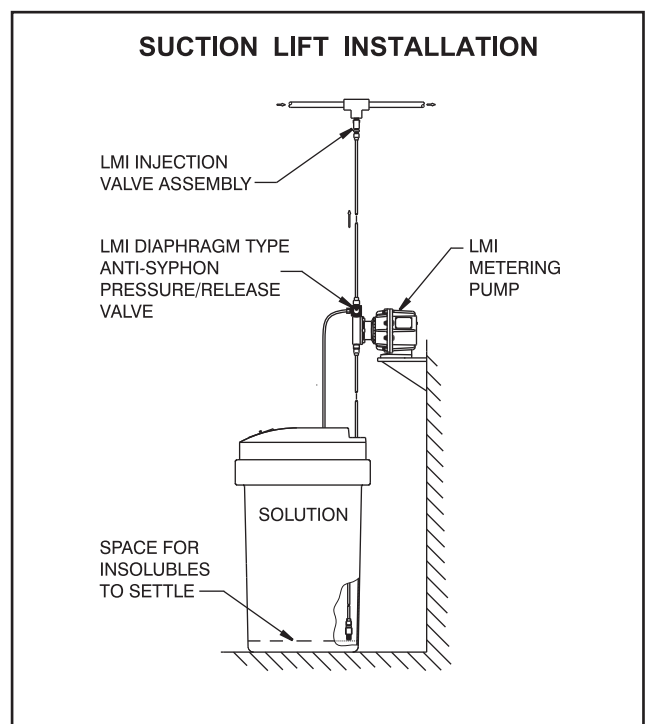

Figure 2

D. BACK PRESSURE REQUIREMENTS

All electronically controlled magnetically driven pumps maintain maximum velocity on the discharge portion of their stroke regardless of the stroke frequency setting. If there is little or no resistance (back pressure), the velocity of the pumped fluid will be so great as to cause over-pumping. Be cause of this characteristic, back pressure equal to approximately 25 psi (1.7 Bar)* must be supplied by an anti-syphon/back pressure valve if the system pressure at the injection point is not high enough to provide the needed back pressure.

* 10 psi (0.7 Bar) for Series E74.

PREVENT SYPHONING

When pumping “downhill” or into pump suction, always use (a) a 4FV at pump discharge and (b) an injection check valve at injection point (see Figure 2 below).

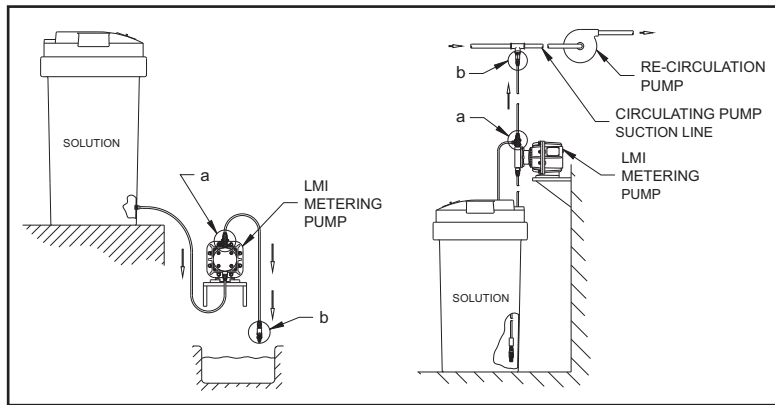

Figure 2

1.3 ELECTRICAL



Installation wiring must conform to U.L. listings and local electrical codes.

Conduit seals must be installed and need to adhere to NEC Article 501-5(a)(b). Installation of drain, breather, or combination fittings is required to guard against water accumulation, which can cause pump failure and compromise the integrity of the explosion-proof enclosure which in turn voids the Series E7 pump warranty.

The external trigger circuit is isolated and has the same characteristics as the other LMI Control Code 7 Series metering pumps. Minimum time in low impedance state (on) is 50 milliseconds. Minimum time in high impedance state (off) is 100 milliseconds.

METHOD OF TRIGGERING A SERIES E PUMP

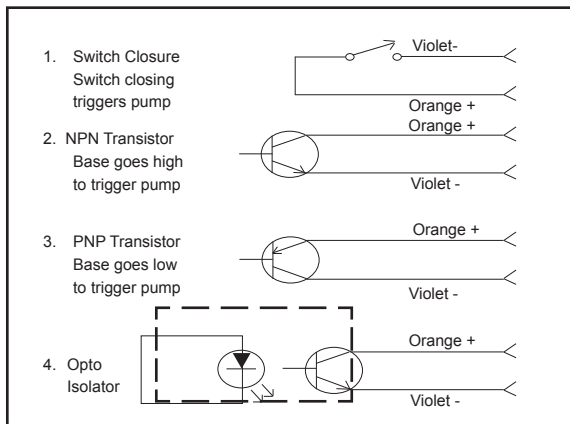

Figure 3

WIRING DIAGRAM

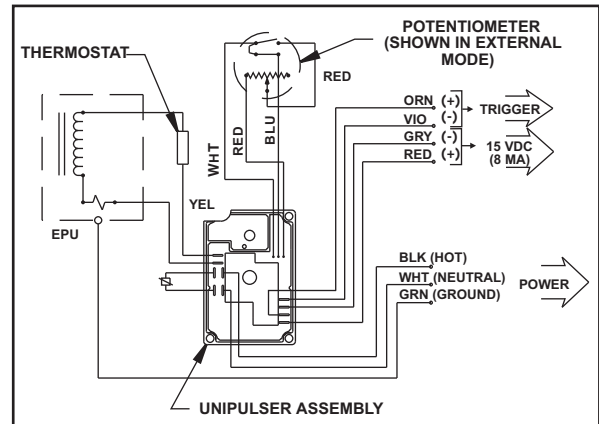

Figure 4

E7 WIRING FOR ACCESSORIES



LMI accessories used with the Series E pumps must be placed in an explosion proof enclosure or located in an area where they will not be subjected to explosion hazard.

WARNING: These accessories are not explosion proof and must be installed remotely in a non-hazardous area or mounted in an explosion proof enclosure. Wiring must adhere to local electrical codes for hazardous locations.



E7 Series metering pumps come equipped with four external control wires for operating the complete line of LMI accessories. Since hardwiring is essential for operating devices in hazardous locations, removal of the four pin connector from the accessory is necessary. The chart below indicates proper wiring for each accessory.

ACCESSORY	ACCESSORY WIRES	E7 WIRES
RFP Flowmeters 26034 Extension Cables	(Pin #) 1 White 2 Black 3 Green 4 Red	Orange Violet Gray Red
DP5000 pH Controllers DR5000 ORP Controllers DX6000 Controllers	1 White 2 BlackGrayRed	Orange Violet Gray (No Connection-wire cap) Red (No Connection-wire cap)
MP-100 Micropace MP-400D Micropace MP-500M MicropaceOrange 2 Black 3 Green 4 White	Orange (No Connection-wire cap) Violet Gray Red
FC Flowmeters 26006 Pulse Transmitter (A7, B7, C7, P7) 41319 Pulse Transmitter (AA7)	1 White 2 BrownGrayRed	Orange Violet Gray (No Connection-wire cap) Red (No Connection-wire cap)

OUTPUT ADJUSTMENT - INITIAL APPROXIMATION

- A. Speed control dial is graduated in approximate percent of maximum strokes per minute (spm). Turning this knob clockwise  increases pumping frequency.

OUTPUT ESTIMATE - Total output of pump may be estimated by multiplying stroke frequency (percent of maximum) by stroke length setting (percent of maximum). For example, if the stroke length knob is set at 100% of maximum and the stroke frequency is 20% of maximum, total pump output will be approximately 20%; if the stroke length knob is set at 30% of maximum and stroke frequency is 20% of maximum, total output will be approximately 6% of the pump's maximum rating. This is $.2 \times .3 = .06$ or 6%.

- B. To determine exact frequency in strokes per minute at any speed knob setting, count number of strokes for one minute.
- C. Stroke length adjustment knob is the lower of the control panel knobs. Adjust by rotating to desired setting, while pump is stroking.
- D. SETTING—Maximum output of the pump is obtained with stroke frequency knob set at maximum and stroke length knob set at maximum.
If pump is to be used at less than maximum output, best volumetric efficiency will be achieved if stroke length knob is left at maximum, and stroke frequency knob rotated counter-clockwise  to reduce pump output. If more output reduction is required than can be achieved by reducing stroke frequency, reduce output by turning the stroke length knob counter-clockwise .
- E. After installation is complete and an initial approximation setting has been made, the pump should be calibrated and the stroke frequency and/or stroke length settings adjusted.
- F. Nominal output and pressure ratings are at 100% settings of stroke frequency and stroke length.

Series	Max. Pressure Rating		Max. Output	
	psi	Bar	GPH	l/h
E70	300	20.7	1.3	4.9
E71	150	10.3	2.5	9.5
E72	100	6.9	4.0	15.1
E73	60	4.1	8.0	30
E74	25	1.7	20.0	76

PROCEDURE FOR ON-SITE VOLUMETRIC CALIBRATION E7 IN INTERNAL MODE

- A. Make certain speed control knob is turned fully clockwise. Turn off power to pump.
- B. With pump primed and discharge tubing connected to the injection point as it would be in normal service, place foot valve and strainer assembly in a graduated container with a volume of 500 ml or more (so that the volume displaced by tubing and foot valve assembly is minimal in relation to volume of the solution in the container).
- C. Turn pump on, and pump until air is exhausted from the suction line and pump head.
- D. Turn pump off, note the solution level in the graduate. Refill graduate if necessary.
- F. Turn off pump at the end of the calibration period, note volume pumped during the calibration period, and calculate volume of solution pumped in the time unit you choose (minute, hour, day, etc.).
- G. Adjust stroke frequency and/or stroke length knobs to your best estimate of required correction, and repeat calibration measurements as a check.

PROCEDURE FOR ON-SITE VOLUMETRIC CALIBRATION OF E7 IN EXTERNAL MODE

- A. Since pump output is governed by an external device, only the output per stroke may be calibrated.
- B. With pump primed and discharge tubing connected to the injection point as it would be in normal service, turn off pump and place foot valve and strainer assembly in a graduated container with a volume of 500 ml or more.
- C. Turn pump to internal mode with speed knob set at 100 and operate until air is exhausted from suction line and pump head.
- D. Turn pump off and note solution level in graduated container. Refill graduate if necessary.
- E. Turn pump on and count the number of strokes for exactly one minute. Then switch pump off.
- F. Note volume pumped during the calibration period of one minute. Divide into this, the number of strokes to determine the volume of solution pumped per stroke.
Example: 50 ml/100 spm = 0.5 ml per stroke.
Multiply this by your expected stroke rate per minute, per hour or per day and compare with desired output requirements.
- G. Adjust stroke length knob (lower knob) to your best estimate of required correction and repeat calibration procedure.



You may elect, for safety and convenience, to do the first calibration or operating test with water or other non-hazardous solution. If so, make certain the water or test fluid is removed from the Liquid End before pumping solutions that may react with the test fluid or be exothermic, such as sulfuric acid.

The final calibration adjustment should be made with pumping conditions identical to conditions of normal pumping service. This means that factors such as injection pressure, fluid viscosity, suction lift and others will automatically be accounted for in making the final adjustment of the pump.

2.0 TROUBLESHOOTING LIQUID END

2.1 LOW PUMP OUTPUT

Low pump output can be caused by many things. Some of the more common ones are:

- Very low stroke setting, i.e. red zone setting of knob
- Trapped air in pump head (trapped air in discharge tubing has no effect)
- Air leak through valve seal rings
- Ruptured pumping Liquifram™ (diaphragm)
- Clogged Liquid End, or injection point connection
- Injection into pressure within 25 psi (1.7 Bar)* of pump's maximum pressure rating with anti-syphon spring in place (if so supplied)
- Injection into pressure in excess of pump rating-see chart on page 6.

* 10 psi (0.7 Bar) for Series E74.

- A. **Very low stroke setting** - Check position of stroke length knob (lower knob) by rotating it counter-clockwise until Liquifram™ (diaphragm) stops moving with the pump operating. The Liquifram™ should not stop reciprocating (moving or clicking) until the knob points to zero. If it stops before zero, reset knob by grasping the knob and pulling it towards you. Pry the yellow cap off of the knob. Place the knob on a flat surface. Using needle nose pliers, squeeze the inner section together while lifting the outer section up (see Figure 5, below).

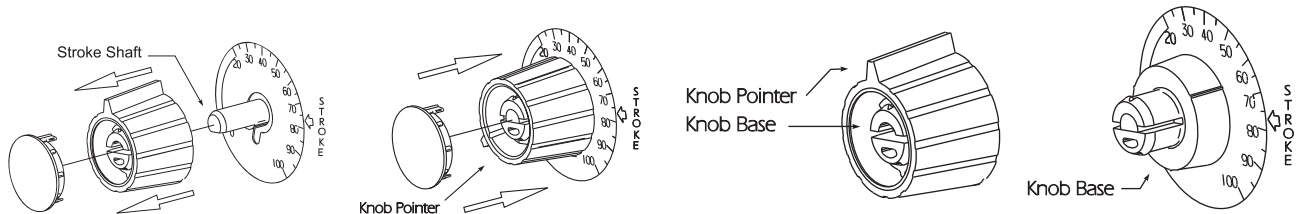

Figure 5

Push the inner section back onto the “D” shaped stroke shaft. With the pump running, zero the pump by turning the inner section of the knob counter clockwise. Position the outer section of the knob so that the pointer aligns with zero on the nameplate. Push down on the outer section of the knob (a snap sound will indicate that parts are locked together). Replace the yellow cap over the outer section of the knob, aligning the tabs on the cap with the slots on the knob.

- B. **Trapped air in pump head** - May be caused by leaks in the suction line, where the suction line joins the suction fitting, or at the seal ring between suction fitting and pump head. It may also be caused by air or gases coming out of solution. Trapped air or bubbles in the discharge line have no effect on the pump's operation. They may be ignored.
- To remove trapped air from the pump head, operate the pump with stroke frequency knob and stroke length knob set at 100.
 - It may be necessary to pull on both knobs of the 4FV, or rotate pressure relief knob ¼ turn, if so equipped. Follow “Priming” instructions in the Liquid Handling Assembly Sheet inserted in this instruction book and operate the pump for a few minutes to purge the head and valves of air or gas.
- C. **Air leak through valve seal rings**- usually caused by worn or damaged seal rings or loose fittings. Tighten fittings by hand until they are very snug. If there is no improvement, replace both seal rings in pump head. See enclosed Liquid Handling Assembly Sheet.



- D. **Ruptured pumping diaphragm**—If rupture is severe and pump is injecting into pressure, solution leak will be obvious through the 3/16" (5 mm) diameter hole at the bottom of the spacer directly behind the pump head. Replace pumping Liquifram™ (diaphragm). If rupture is a small pin hole, there may be oozing of solution through the 3/16" (5 mm) diameter hole described above. Replacement of pumping Liquifram™ (diaphragm) will be necessary.
- E. **Clogged Liquid End**—will cause low pump output. Purge Liquid End. Disassemble Liquid End. Clean individual parts with water and detergent or appropriate cleaning solution.
- F. **Injection into excessive pressure**—If discharge pressure is within 25 psi (1.7 Bar)* of maximum pump rating, remove spring in injection check valve, if so supplied.
* 10 psi (0.7 Bar) for Series E74.

2.2 EXCESSIVE PUMP OUTPUT

- A. **Syphoning**—If your Series E pump has a Liquid End other than a high viscosity LE, its injection check valve assembly has a chemically resistant anti-syphon spring. Disassemble the injection check valve and check to be sure this spring is in place and undamaged. Replace if necessary.

Note that the anti-syphon spring must be removed if injection is into a pressure within 25 psi (1.7 Bar)* of pump's maximum pressure rating. Liquid Ends with a suffix "S" have, in addition, a diaphragm type anti-syphon valve, which prevents syphoning and over pumping.

* 10 psi (0.7 Bar) for Series E74.



- B. **Incorrect knob settings**—Check stroke length knob (lower knob) by rotating it counter-clockwise  to zero position. The Liquifram™ (pumping diaphragm) should stop reciprocating. If it does not, reset knob and continue counter-clockwise rotation until motion stops. Reset knob by grasping the knob and pulling it towards you. Pry the yellow cap off of the knob. Place the knob on a flat surface. Using needle nose pliers, squeeze the inner section together while lifting the outer section up (see Figure 5). Push the inner section back onto the "D" shaped stroke shaft. With the pump running, zero the pump by turning the inner section of the knob counter-clockwise . Position the outer section of the knob so that the pointer aligns with zero (0) on the nameplate. Push down on the outer section of the knob (a snap sound will indicate that parts are locked together). Replace the yellow cap over the outer section of the knob, aligning the tabs on the cap with the slots on the knob.

2.3 CHANGING PUMPING LIQUIFRAM™ (DIAPHRAGM)

- A. Make sure size code marking (0.9 S.I., 1.8 S.I. or 3.0 S.I.) on spacer and Liquifram™ (diaphragm) are the same. Liquifram™ and spacer size code must match in order for the pump to function. The E74 Liquifram™ size code is 6.0 S.I., (spacer is 3.0 S.I., but there is a large black spacer adapter).



Always wear protective clothing, gloves and face shield when working on or near chemical metering pumps.

- B. Depressurize discharge line following steps outlined on the supplement "Liquid Handling Assembly Instructions". Lift foot valve from solution and let pump run pumping air for a few minutes. Then remove pump head.
- C. Set stroke length knob (lower knob) to zero, rotate it counter-clockwise  with the pump running, then stop the pump by turning stroke frequency knob (upper knob) to "off".
- D. Lift edge of Liquifram™ and rotate it counter-clockwise  to unscrew the Liquifram™.
- E. Before installing new pumping Liquifram™, turn pump on and rotate stroke length control knob (lower knob) to the proper setting per the following table:

Model	Stroke Setting Length
E70, E71, E72	90%
E73, E74	70%

- With pump stroking, screw on new Liquifram™ until the center part begins to buckle inwards during the latter half of the stroke. Turn pump off and check Liquifram™ position with a straight edge according to Figure 6 (below).
- If Liquifram™ setting is not correct, restart pump then screw the Liquifram™ in or out. Always stop pump electrically when checking Liquifram™ setting. Repeat procedure if necessary.
- After Liquifram™ is set properly, restart pump and turn stroke knob to 100%.

F. Re-install pump head and tighten head mounting screws in criss-cross pattern.

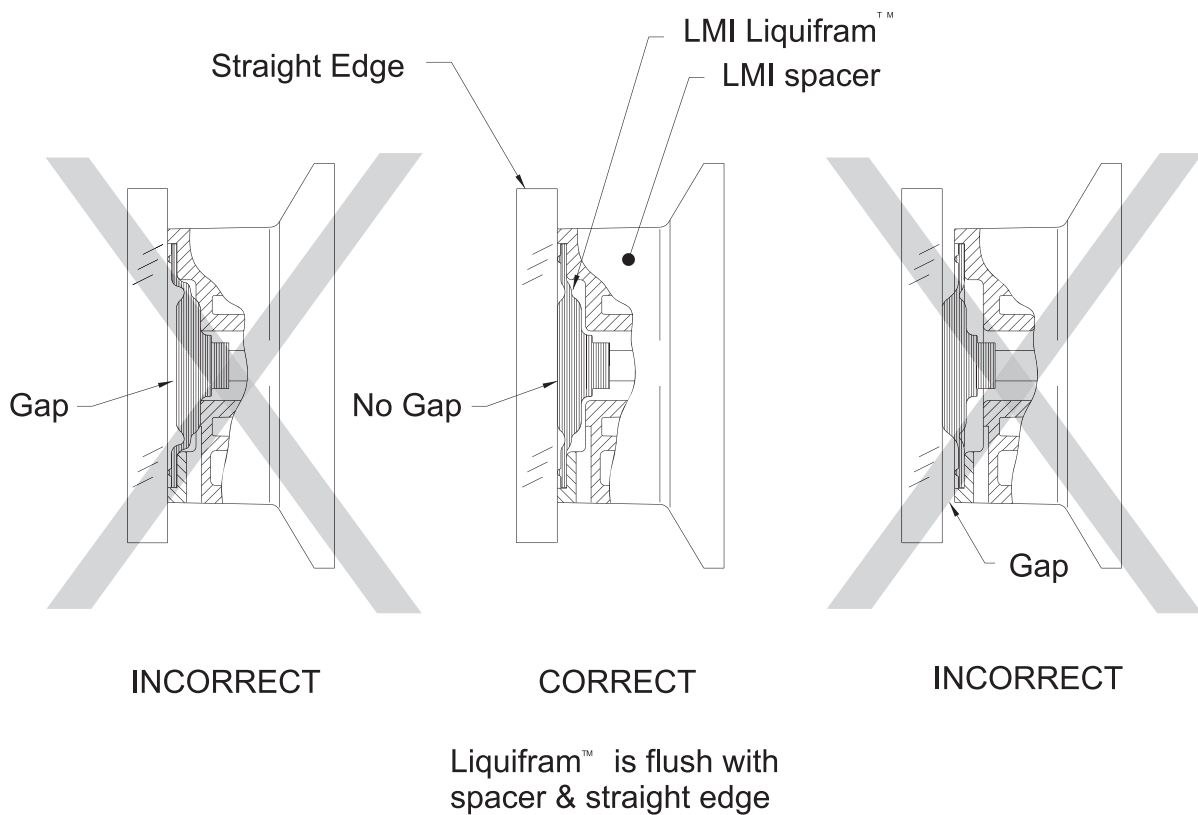
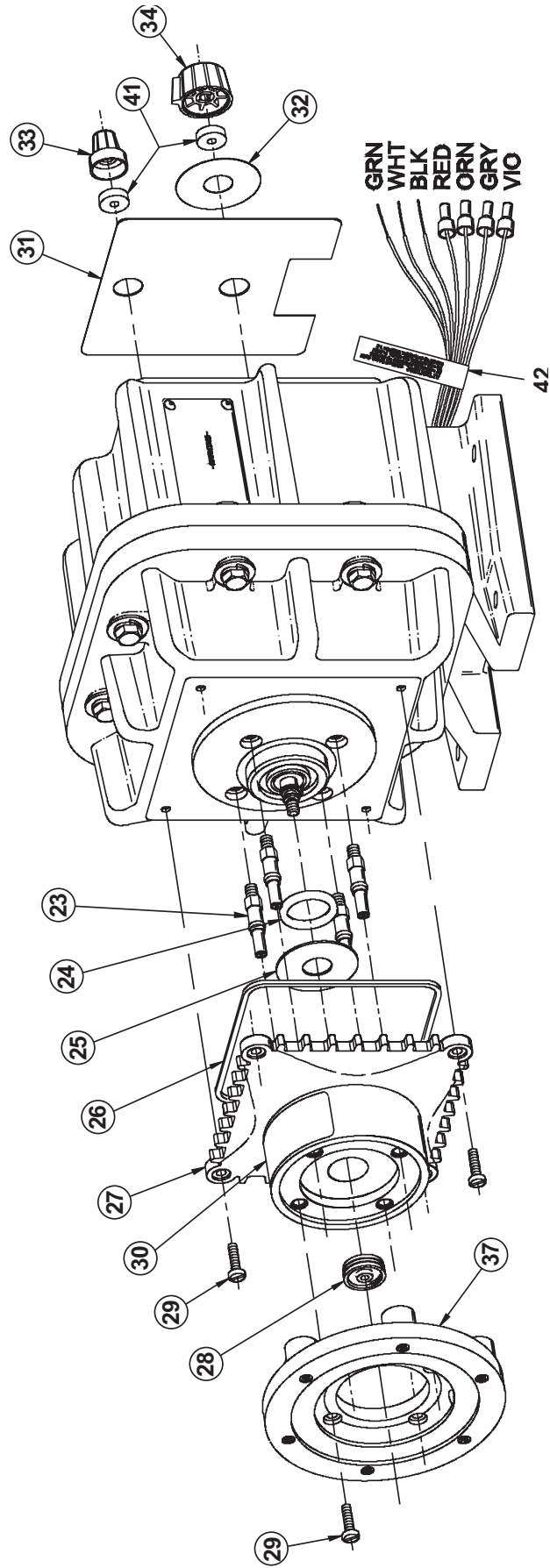

Figure 6

3.0 EXPLODED VIEW



4.0 PARTS LIST

Key No.	For Model No.	Part No.	Description	Quantity
23	E70, E71, E72	27641	Stud	4
	E73, E74	29605	Stud	4
24	E7	26983	O-Ring	1
25	E7	27586	Shim	1
26	E7	35269	Seal	1
27	E70	35837	Spacer, 0.9	1
	E71, E72	35838	Spacer, 1.8	1
	E73, E74	35839	Spacer, 3.0	1
28	E7	10973	Shaft Seal	1
29	E70, E71, E72, E73	10598	Screw, 10-24 S.S.	4
	E74	10598	Screw, 10-24 S.S.	8
30	E7	25452	Label	1
31	E7	31542	Nameplate	1
32	E70, E71	32465	Stroke Dial	1
	E72	32466	Stroke Dial	1
	E73	32467	Stroke Dial	1
	E74	32468	Stroke Dial	1
33	E7	25889	Knob Asm., Speed	1
34	E7	31891	Knob Asm., Stroke	1
37	E74	25887	Adapter, 6.0 SI	1
41	E7	30803	Gasket	1
42	E7	48340	Wire Tab Label	1



201 Ivyland Road
Ivyland, PA 18974 USA
TEL: (215) 293-0401
FAX: (215) 293-0445
<http://www.lmipumps.com>